



# HIGHBRIDGE PARK

ANCHOR PARKS PROGRAM:

CONCEPTUAL MASTER PLAN

Located along Amsterdam Avenue / Fort George Avenue from 155th Street to Dyckman Street, in the Borough of Manhattan

Community Board 12 Parks & Cultural Affairs Committee Presentation  
March 7, 2017

MKW + Associates, Parks Capital Design

# Parks

# TONIGHT'S AGENDA

**1/ Introduction**

**2/ Highbridge Park Conceptual Master Plan**

**3/ Anchor Parks Phase 1 Schematic Design**

**5/ Next Steps**





OUR COMMITMENT: CREATE  
**A BRIGHT, GREEN FUTURE**  
WITH A MORE INCLUSIVE  
AND INNOVATIVE  
PARK SYSTEM

# ANCHOR PARKS | Overview

OUR OLD PARKS ARE OUR NEW PARKS...

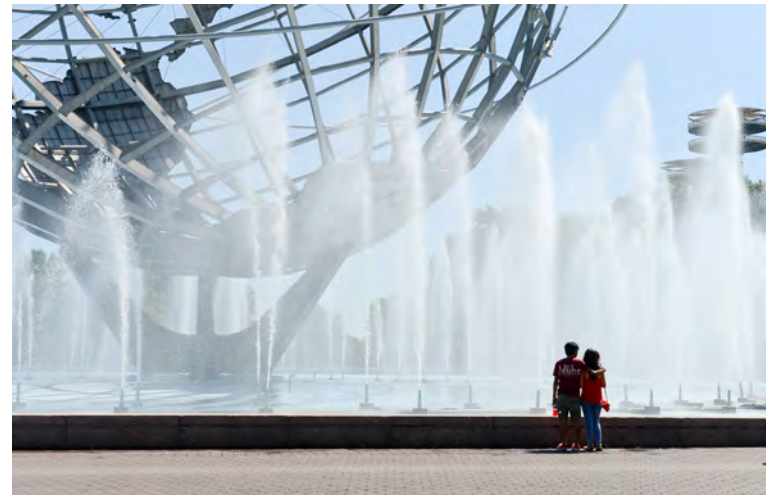

NYC Parks

Anchor Parks | Highbridge Park | Manhattan, NY

# ANCHOR PARKS | Overview

NYC PARKS WILL INVEST \$150 MILLION  
TO RENOVATE FIVE NEIGHBORHOOD  
ANCHOR PARKS —

ONE IN EACH BOROUGH



# HIGHBRIDGE PARK: 130 ACRES OF...

- The City's Oldest Standing Bridge
- Historic Water Tower
- Year-round Recreation Center
- Competition Sized Swimming Pool
- Wading Pool
- World Class Skate Park
- 2.5-Mile Mountain Biking Course
- BMX Jump Track
- Playgrounds (7)
- Ballfields (3)
- Basketball Courts (7.5)
- Handball Courts (3)
- Volleyball Courts
- Natural Areas
- Dog Run
- John T. Brush Stairway

# NYC PARKS' NOVEMBER 2016 VISIONING



**140 PEOPLE** SHARED  
THEIR IDEAS AND HOPES  
FOR HIGHBRIDGE PARK



NYC Parks

Anchor Parks | Highbridge Park | Manhattan, NY

# NYC PARKS' JANUARY 2017 COMMUNITY REPORT BACK MEETING



NYC Parks

Anchor Parks | Highbridge Park | Manhattan, NY

**70 PEOPLE ATTENDED**



# Goals

- Improve connectivity and access including mid-level path to the High Bridge, north and south park connections, and linkage to the Polo Grounds houses
- Improve quality of play and recreational experiences: reconstruct Adventure Playground and Fort George Playground
- Provide additional sports fields / practice fields
- Provide much-needed bathrooms / restrooms
  - New bathroom at Adventure Playground
  - New restrooms at Highbridge Pool bleachers
  - New bathroom at Fort George Playground
- Provide outdoor gathering / picnic / event spaces
- Improve ADA access to Recreation Center
- Improve safety and security: provide park lighting
- Improve forest ecology and undertake forest restoration
- Complete restoration of historic Water Tower
- Add Highbridge Park signage / directories
- Improve / enhance park entrances / gateways

**Project Size:** 130 ac



NYC Parks



**Highbridge Park | Project Goals**



City

2 MI



Neighborhood

1000 FT

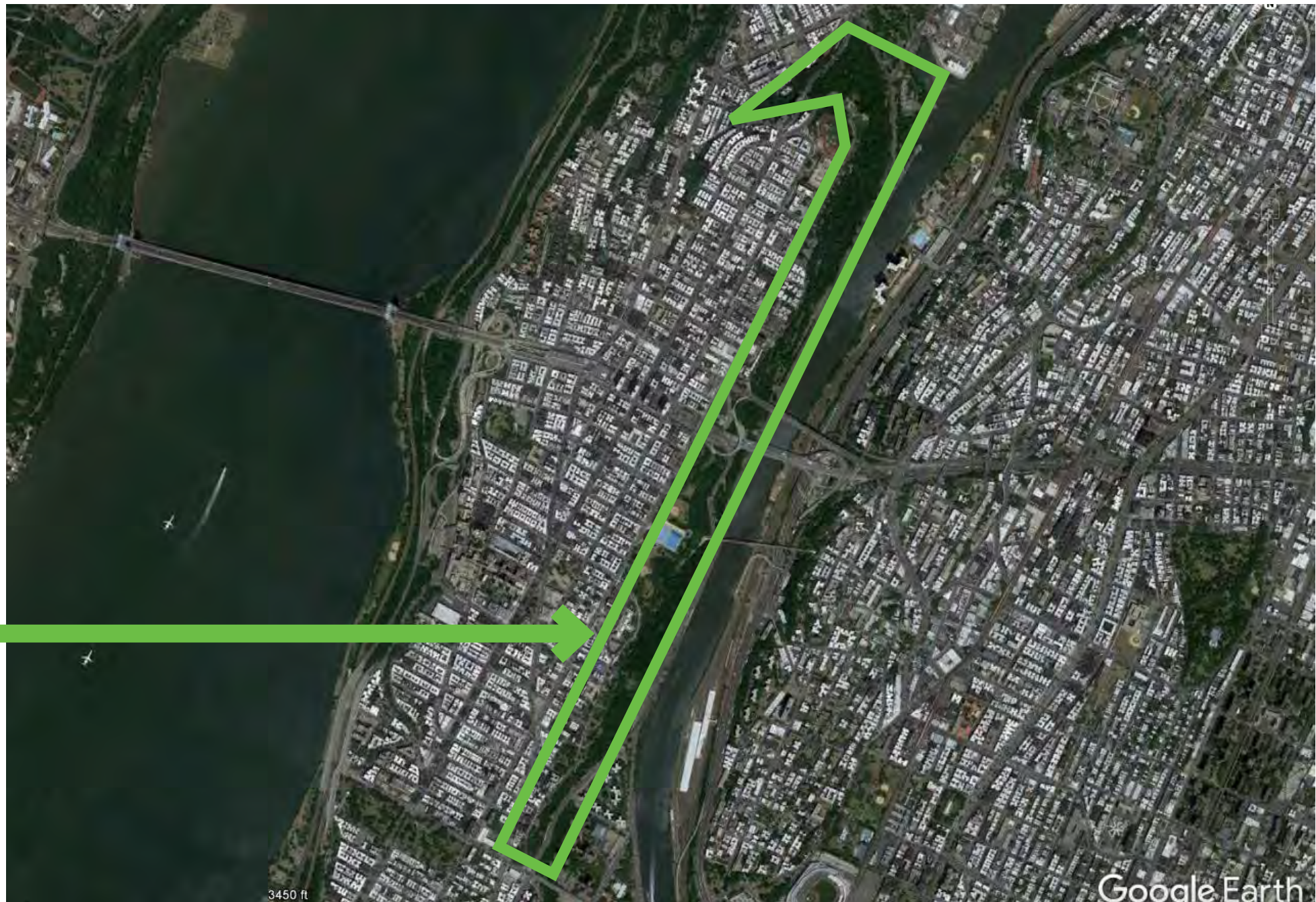

Site

500 FT



NYC Parks



# Highbridge Park | Site Location



## Flood Hazard Zones

- ZONE A** - 1% annual-chance flood event. No Base Flood Elevation (BFE) exists.
- ZONE AE** - 1% annual-chance flood event. BFE exists.
- ZONE AO** - 1% annual-chance shallow flooding.
- VE** - Areas along coasts subject to inundation by the 1% annual-chance flood event with additional hazards associated with storm-induced velocity wave action. BFE exists.
- FLOODWAY** - watercourse reserved to discharge base flood.
- ZONE X** - Moderate risk areas within the 0.2% annual-chance floodplain.
- LIMIT OF MODERATE WAVE ACTION**



## Highbridge Park | Flood Risk

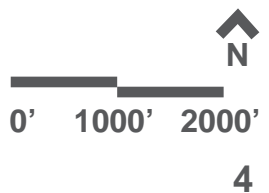



## Land Use Categories

- 1 And 2 Family Residential
- Multi-Family Residential
- Mixed Use
- Open Space And Outdoor Recreation
- Commercial
- Institutional
- Industrial
- Parking
- Transportation / Utilities
- Vacant Lots



NYC Parks



## Highbridge Park | Surrounding Land Use

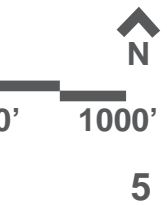



1 - View to Sugar Hill Luminaries Lawn at right and typical sidewalk treatment along this part of Edgemcombe Avenue on the left.



2 - View to a portion of Adventure Playground.





**3 - Sunken Playground consists of handball and basketball courts and sitting areas well below the adjacent sidewalk grade.**



**4 - Steps down into a depressed area along Edgecombe Avenue, originally designed as horseshoe pitches.**



## Highbridge Park | Site Photos

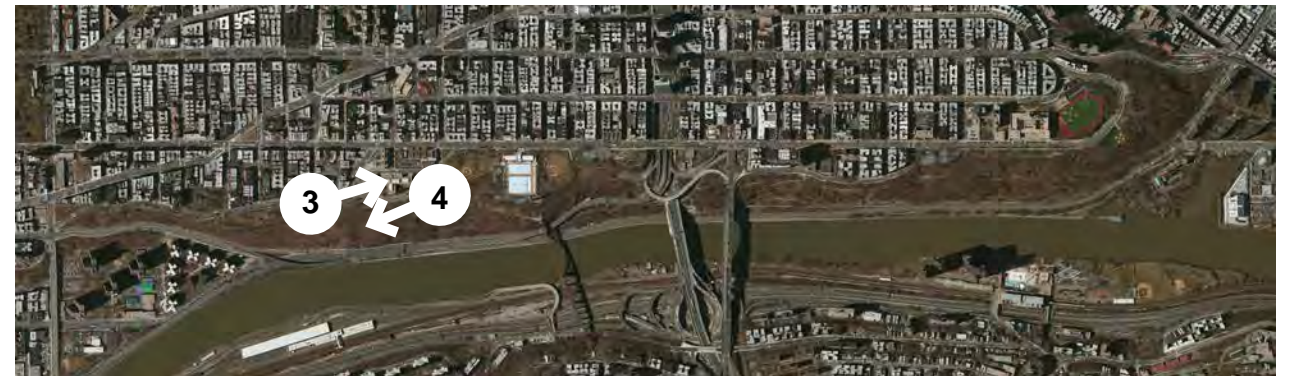



5 - Panoramic view of grade differential at Highbridge Recreation Center and sidewalk along Amsterdam Avenue.



## Highbridge Park | Site Photos





6 - View of Highbridge Water Tower Plaza with the existing swimming pool to the left.



7 - A portion of Fort George Playground illustrating the expansive spray shower area.







**8 - Dyckman Rest, previously a playground, contains expansive asphalt, some mature trees and occasional benches only.**



# SOUTH SECTION

# MID SECTION

# NORTH SECTION



NYC Parks



## Highbridge Park | Site Analysis



# LEGEND

- PROJECT LIMITS
- PATHS
- STAIRS
- TRAILS
- ROADS
- AQUEDUCT TRAIL
- NO PARK ACCESS
- ↓ ↓ ↓ STEEP SLOPE
- ↔ PARK ENTRANCE
- 150.00 SPOT ELEVATION
- BUILDING + STRUCTURES
- OPEN SUNNY PLAY AREA
- OUTDATED PLAY EQUIPMENT
- HEAVY TRAFFIC CROSSING
- UNDERPERFORMING SOCIAL SPACE
- SPRAY SHOWER
- GATHERING
- OVERLOOK / VIEW
- BATHROOM
- BASEBALL
- BASKETBALL
- HANDBALL
- PLAYGROUND

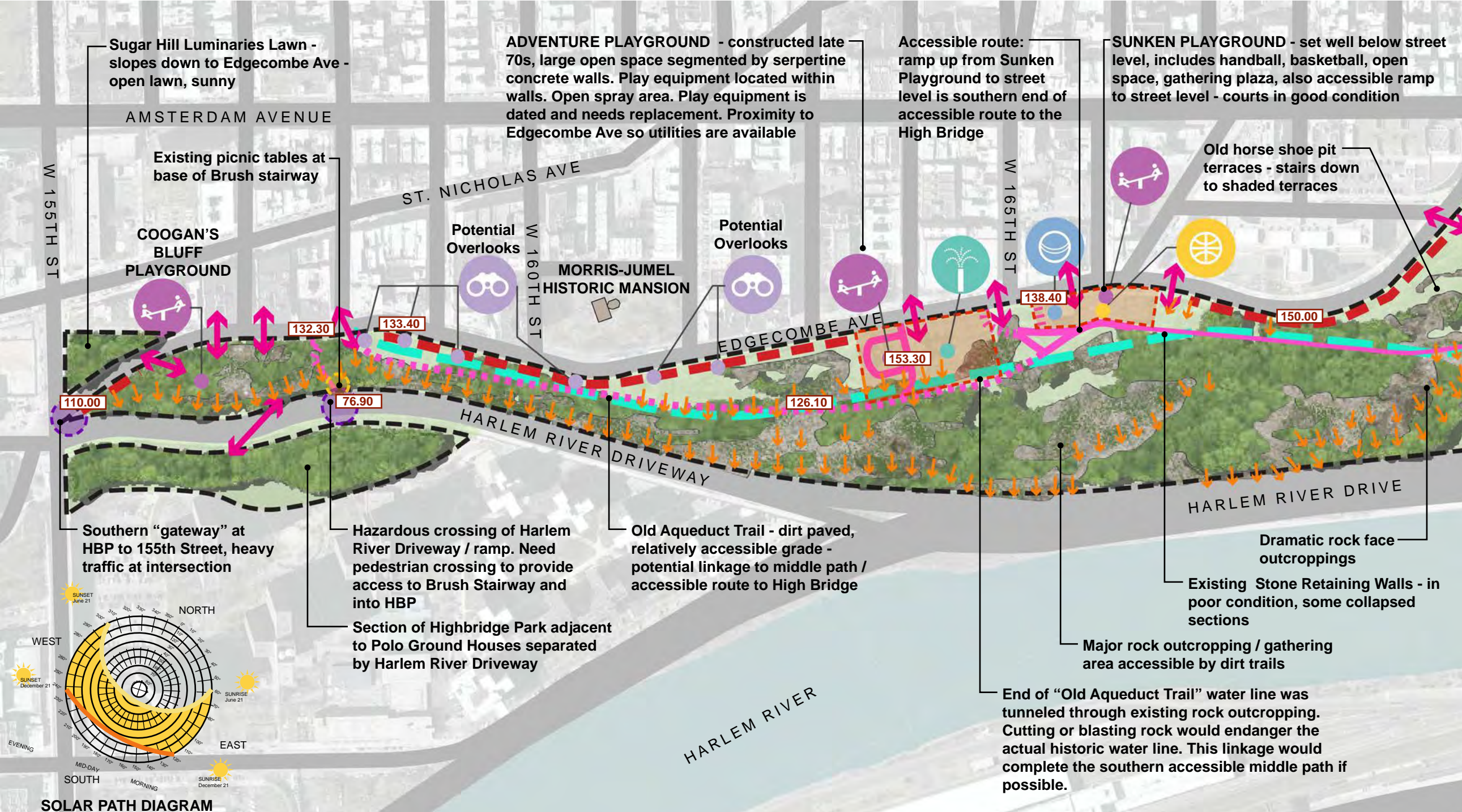

MATCHLINE - SEE MID SECTION

Sugar Hill Luminaries Lawn - slopes down to Edgcombe Ave - open lawn, sunny

ADVENTURE PLAYGROUND - constructed late 70s, large open space segmented by serpentine concrete walls. Play equipment located within walls. Open spray area. Play equipment is dated and needs replacement. Proximity to Edgcombe Ave so utilities are available

Accessible route: ramp up from Sunken Playground to street level is southern end of accessible route to the High Bridge

SUNKEN PLAYGROUND - set well below street level, includes handball, basketball, open space, gathering plaza, also accessible ramp to street level - courts in good condition

Old horse shoe pit terraces - stairs down to shaded terraces

W 155TH ST

AMSTERDAM AVENUE

Existing picnic tables at base of Brush stairway

ST. NICHOLAS AVE

COOGAN'S BLUFF PLAYGROUND

Potential Overlooks

MORRIS-JUMEL HISTORIC MANSION

Potential Overlooks

W 165TH ST

EDGECOMBE AVE

HARLEM RIVER DRIVEWAY

HARLEM RIVER DRIVE

HARLEM RIVER

Southern "gateway" at HBP to 155th Street, heavy traffic at intersection

Hazardous crossing of Harlem River Driveway / ramp. Need pedestrian crossing to provide access to Brush Stairway and into HBP

Old Aqueduct Trail - dirt paved, relatively accessible grade - potential linkage to middle path / accessible route to High Bridge

Dramatic rock face outcroppings

Existing Stone Retaining Walls - in poor condition, some collapsed sections

Major rock outcropping / gathering area accessible by dirt trails

End of "Old Aqueduct Trail" water line was tunneled through existing rock outcropping. Cutting or blasting rock would endanger the actual historic water line. This linkage would complete the southern accessible middle path if possible.

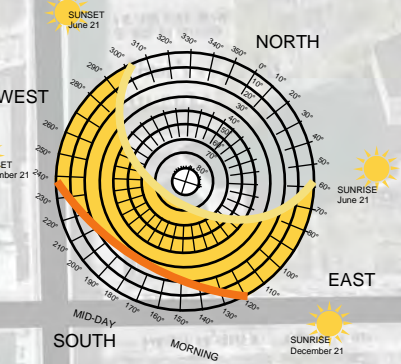

SOLAR PATH DIAGRAM

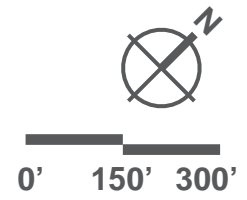

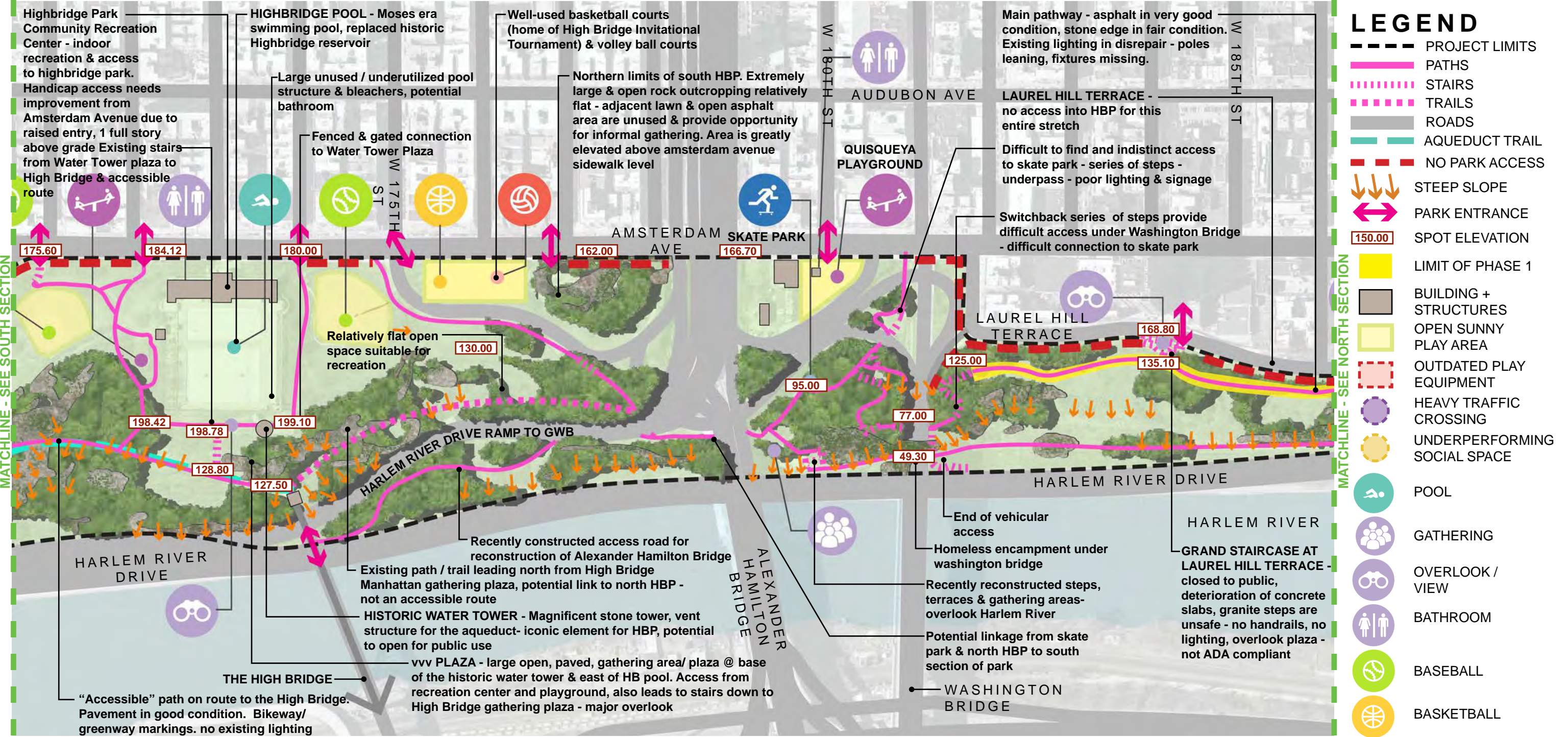

**Highbridge Park | Site Analysis Diagram - Mid Section**

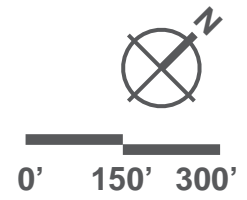

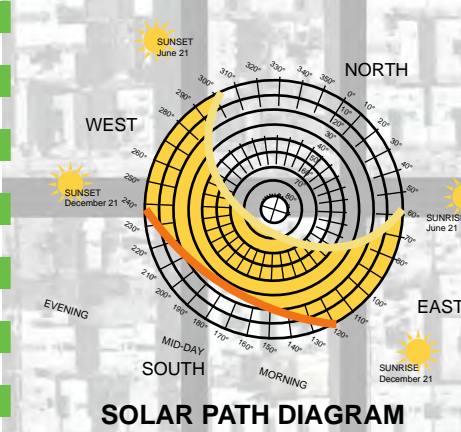

**FORT GEORGE PLAYGROUND** - Large, asphalt-paved open space, outdated playground & spray area - unused large space accessed from sidewalk

Triangular seating plaza at corner of Dyckman, Fort George Hill, & Nagle Ave - Potential gateway, improve seating area / plaza

**Raoul Wallenburg Playground** in fair condition: Play equipment & spray shower needs updating, existing bathroom in good condition

Juan Bosch sitting area / plaza in good condition

Dog Run in good condition

**DYCKMAN'S REST**- large, open asphalt area, perimeter seating & shade trees, on grade with sidewalk - unused open space

Entry plaza / gateway to north end of HB - relatively flat grade

**MOUNTAIN BIKE COURSE** - dirt trails with some erosion, good mapping / signage

Pathway along Harlem River Drive in fair condition

**BUCZEK FIELD** - Synthetic turf recently installed, existing basketball courts in good condition

Existing stone retaining walls vary in condition from sound / good to unsound, poor - some repair of collapsed section, needs repointing and mortaring throughout

Stairs at 187th Street closed to public - fenced off, deterioration of steps and stone walls, unsafe

Steep slopes and rock outcropping throughout, some eroded areas

Existing asphalt path down to Dyckman street in fair condition - no existing lighting or power - pathway gradient is steep, not accessible

- ### LEGEND
- PROJECT LIMITS
  - PATHS
  - ⋯ STAIRS
  - ⋯ TRAILS
  - ROADS
  - NO PARK ACCESS
  - ↓ ↓ ↓ STEEP SLOPE
  - ↔ PARK ENTRANCE
  - 150.00 SPOT ELEVATION
  - LIMIT OF PHASE 1
  - BUILDING + STRUCTURES
  - OPEN SUNNY PLAY AREA
  - OUTDATED PLAY EQUIPMENT
  - HEAVY TRAFFIC CROSSING
  - UNDERPERFORMING SOCIAL SPACE
  - SPRAY SHOWER
  - GATHERING
  - OVERLOOK / VIEW
  - BATHROOM
  - BASEBALL
  - BASKETBALL
  - PLAYGROUND
  - MOUNTAIN BIKE TRAILS
  - BMX BIKE PARK
  - DOG PARK

MATCHLINE - SEE MID SECTION

## Highbridge Park | Site Analysis Diagram - North Section

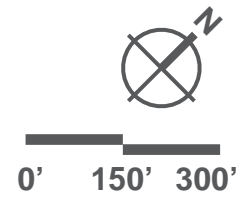

# SOUTH SECTION

# MID SECTION

# NORTH SECTION







## Highbridge Park | Conceptual Master Plan Key Plan





# LEGEND

-  PATHS
-  STAIRS
-  TRAILS
-  SPOT ELEVATION

MATCHLINE - SEE MID SECTION



NYC Parks



## Highbridge Park | Conceptual Master Plan - South Section





# LEGEND

- PATHS
- STAIRS
- TRAILS
- SPOT ELEVATION

MATCHLINE - SEE MID SECTION



NYC Parks







## Highbridge Park | Conceptual Master Plan - South Section







# LEGEND

-  PATHS
-  STAIRS
-  TRAILS
-  SPOT ELEVATION

MATCHLINE - SEE MID SECTION



NYC Parks



Landscape Architecture | Site Planning | Urban Design

## Highbridge Park | Conceptual Master Plan - South Section





# LEGEND

- PATHS
- STAIRS
- TRAILS
- SPOT ELEVATION

MATCHLINE - SEE MID SECTION



NYC Parks







## Highbridge Park | Conceptual Master Plan - South Section





# LEGEND

-  PATHS
-  STAIRS
-  TRAILS
-  SPOT ELEVATION



NYC Parks







## Highbridge Park | Conceptual Master Plan - South Section





# LEGEND

-  PATHS
-  STAIRS
-  TRAILS
-  SPOT ELEVATION

MATCHLINE - SEE MID SECTION



NYC Parks







## Highbridge Park | Conceptual Master Plan - South Section





# LEGEND

-  PATHS
-  STAIRS
-  TRAILS
-  SPOT ELEVATION

MATCHLINE - SEE MID SECTION



NYC Parks







Landscape Architecture | Site Planning | Urban Design

## Highbridge Park | Conceptual Master Plan - South Section





# LEGEND

-  PATHS
-  STAIRS
-  TRAILS
-  SPOT ELEVATION



NYC Parks



## Highbridge Park | Conceptual Master Plan - South Section





# LEGEND

- PATHS
- STAIRS
- TRAILS
- 150.00 SPOT ELEVATION

MATCHLINE - SEE MID SECTION

**New connection to complete linkage of Croton Aqueduct trail and accessible route to the High Bridge. May require "bridge" path from Sunken Playground to avoid cutting or blasting rock**



NYC Parks



**MKW** + ASSOCIATES, LLC.  
Landscape Architecture | Site Planning | Urban Design

## Highbridge Park | Conceptual Master Plan - South Section



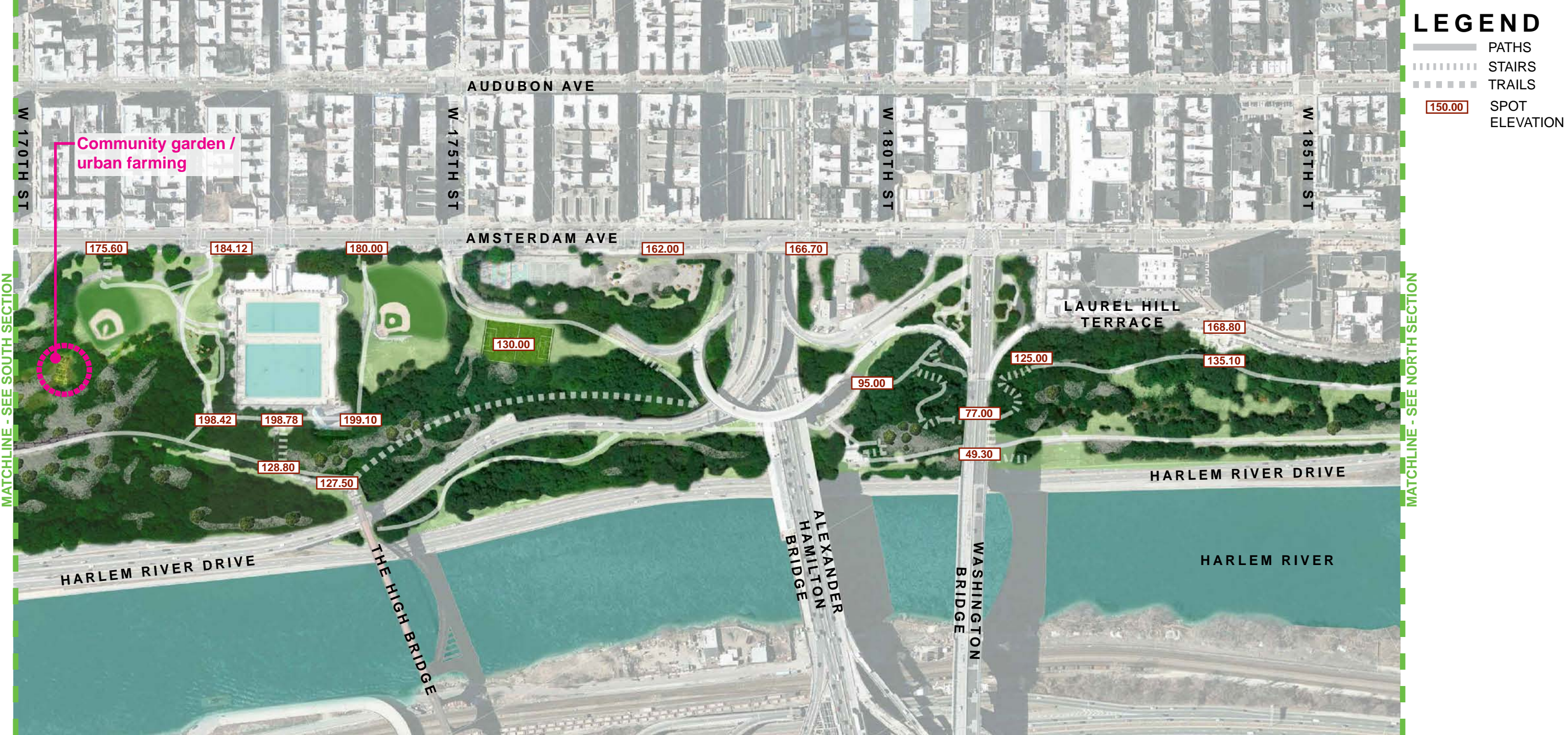

NYC Parks



# Highbridge Park | Conceptual Master Plan - Mid Section

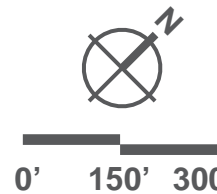



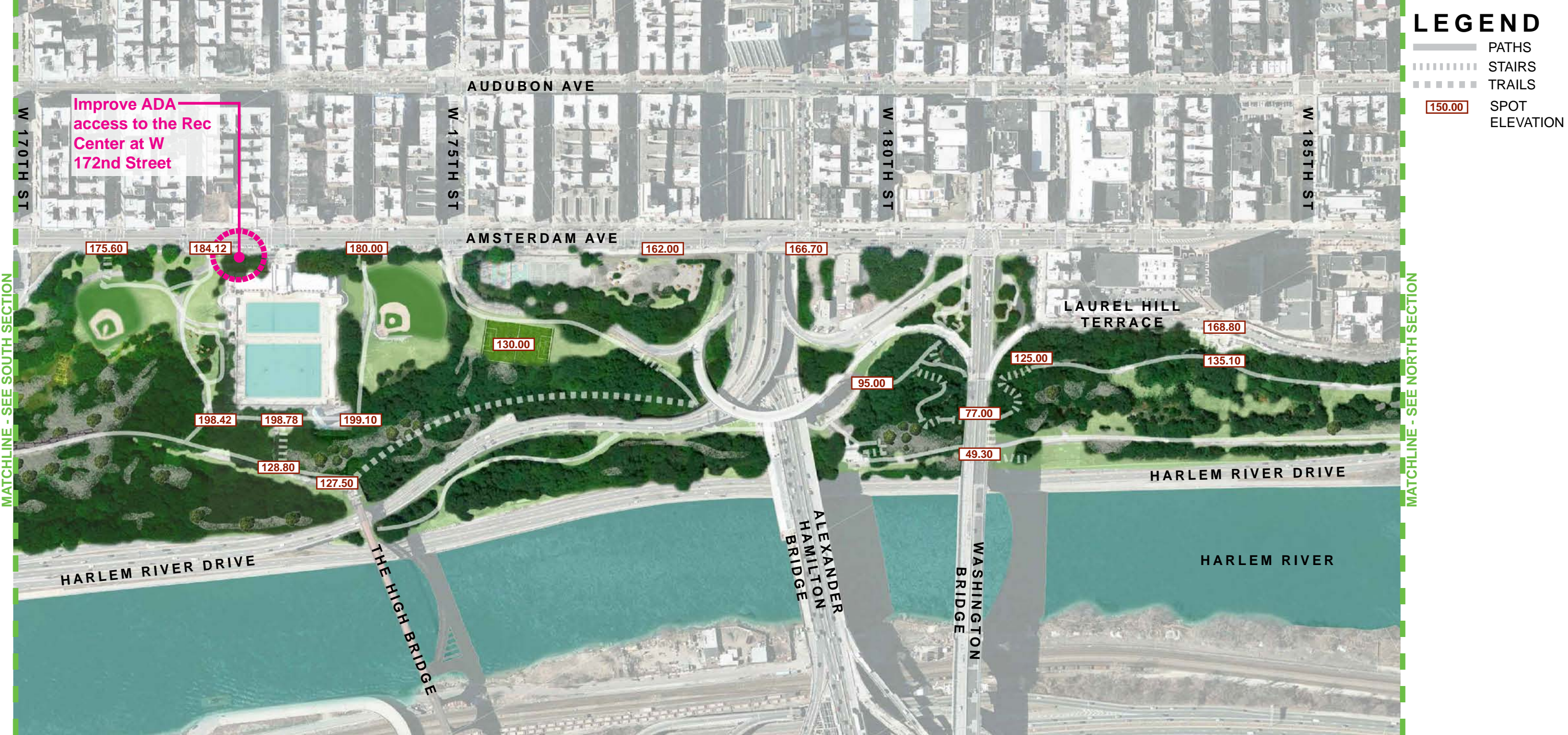

NYC Parks



# Highbridge Park | Conceptual Master Plan - Mid Section

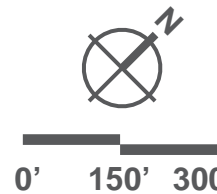

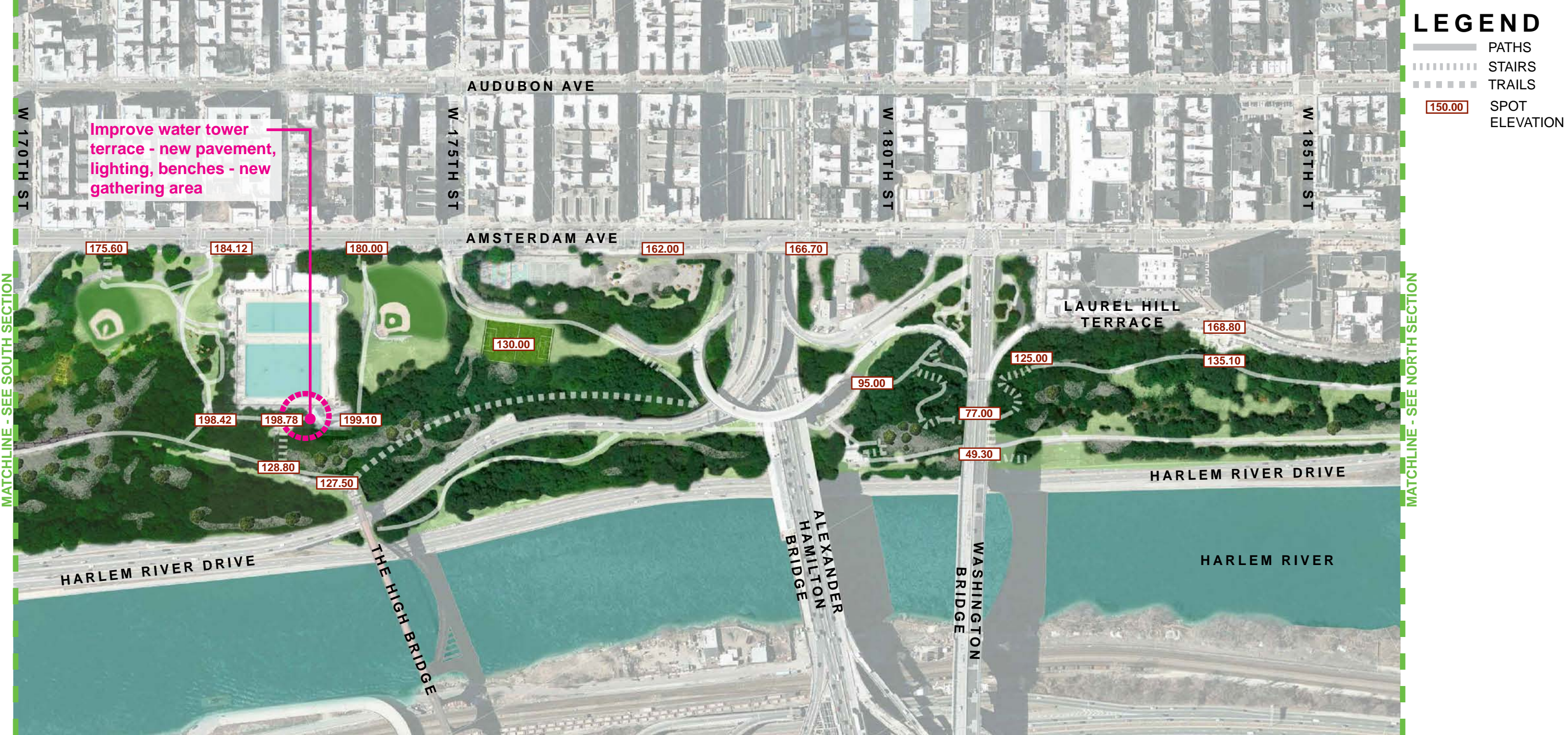

NYC Parks



# Highbridge Park | Conceptual Master Plan - Mid Section

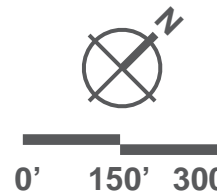

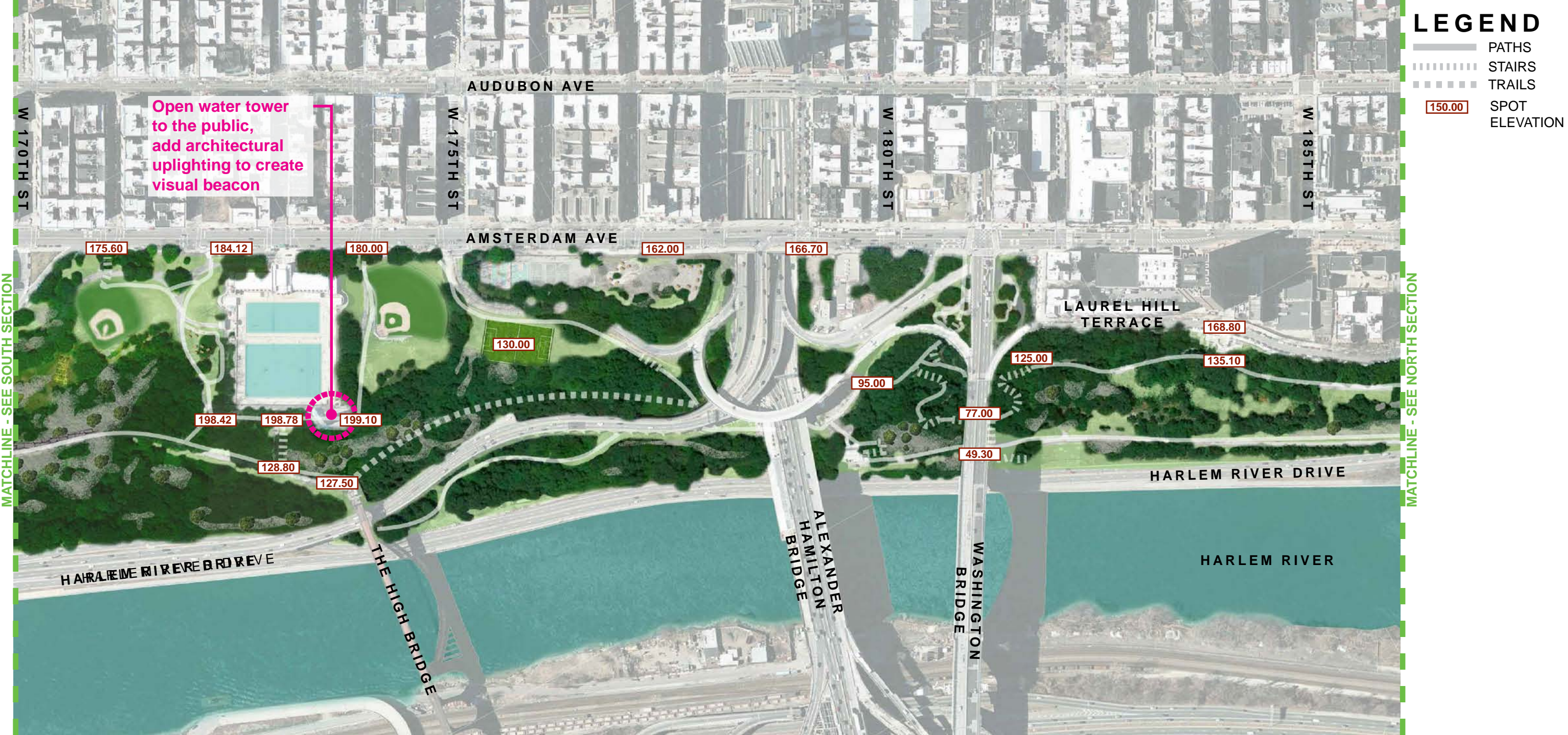

NYC Parks



# Highbridge Park | Conceptual Master Plan - Mid Section

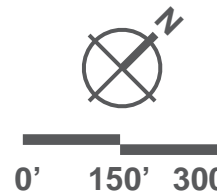



NYC Parks



# Highbridge Park | Conceptual Master Plan - Mid Section

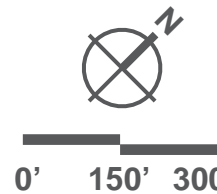



NYC Parks



# Highbridge Park | Conceptual Master Plan - Mid Section

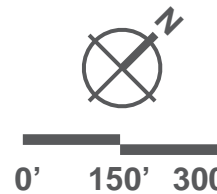



NYC Parks



Highbridge Park | Conceptual Master Plan - Mid Section

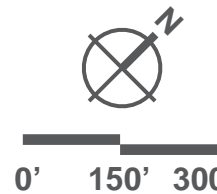



NYC Parks



Highbridge Park | Conceptual Master Plan - Mid Section

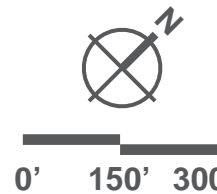



# LEGEND

-  PATHS
-  STAIRS
-  TRAILS
-  SPOT ELEVATION

MATCHLINE - SEE SOUTH SECTION

MATCHLINE - SEE NORTH SECTION



NYC Parks



## Highbridge Park | Conceptual Master Plan - Mid Section



0' 150' 300'





NYC Parks



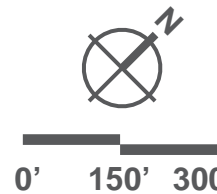

# Highbridge Park | Conceptual Master Plan - Mid Section





# LEGEND

-  PATHS
-  STAIRS
-  TRAILS
-  SPOT ELEVATION

MATCHLINE - SEE SOUTH SECTION

MATCHLINE - SEE NORTH SECTION



NYC Parks



## Highbridge Park | Conceptual Master Plan - Mid Section

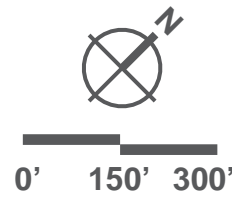



NYC Parks



# Highbridge Park | Conceptual Master Plan - Mid Section

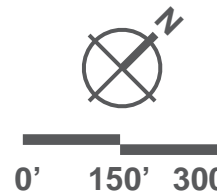



# LEGEND

-  PATHS
-  STAIRS
-  TRAILS
-  SPOT ELEVATION

MATCHLINE - SEE SOUTH SECTION

MATCHLINE - SEE NORTH SECTION



NYC Parks



## Highbridge Park | Conceptual Master Plan - Mid Section

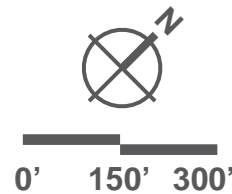



NYC Parks



**Highbridge Park | Conceptual Master Plan - Mid Section**

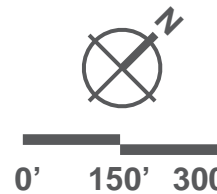



# LEGEND

- PATHS
- STAIRS
- TRAILS
- SPOT ELEVATION

MATCHLINE - SEE SOUTH SECTION

MATCHLINE - SEE NORTH SECTION



NYC Parks



## Highbridge Park | Conceptual Master Plan - Mid Section

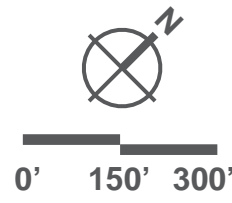



MATCHLINE - SEE MID SECTION

- LEGEND**
- PATHS
  - STAIRS
  - TRAILS
  - SPOT ELEVATION

Repair & Restore stairway at 187th Street - improve access to HBP



NYC Parks



# Highbridge Park | Conceptual Master Plan - North Section

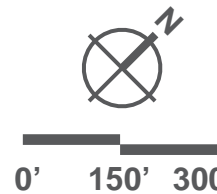





MATCHLINE - SEE MID SECTION

- LEGEND**
- PATHS
  - STAIRS
  - TRAILS
  - SPOT ELEVATION



NYC Parks



# Highbridge Park | Conceptual Master Plan - North Section



0' 150' 300'



**LEGEND**

- PATHS
- STAIRS
- TRAILS
- SPOT ELEVATION

MATCHLINE - SEE MID SECTION

ST. NICHOLAS AVE

W 186TH ST  
W 188TH ST  
W 190TH ST  
W 192ND ST

AUDUBON AVE

AMSTERDAM AVE

LAUREL HILL TERRACE

HARLEM RIVER DRIVE

HARLEM RIVER

FORT GEORGE HILL  
FORT GEORGE AVE

DYCKMAN ST

10TH AVE

Repair / restore stone retaining wall



- LEGEND**
- PATHS
  - ⋯ STAIRS
  - - - TRAILS
  - 150.00 SPOT ELEVATION

MATCHLINE - SEE MID SECTION

**New entry plaza / gateway to HBP (ADA accessible) - new pavements, planting, lighting, signage - "gateway icon"**



**LEGEND**

- PATHS
- STAIRS
- TRAILS
- SPOT ELEVATION

MATCHLINE - SEE MID SECTION



NYC Parks



# Highbridge Park | Conceptual Master Plan - North Section







0' 150' 300'



MATCHLINE - SEE MID SECTION

New sitting / gathering plaza,  
potential food concession,  
"gateway icon"

# LEGEND

-  PATHS
-  STAIRS
-  TRAILS
-  SPOT ELEVATION
-  ELEVATION

ST. NICHOLAS AVE

W 186TH ST

W 188TH ST

W 190TH ST

W 192ND ST

FORT GEORGE HILL

FORT GEORGE AVE

AUDUBON AVE

DYCKMAN ST

AMSTERDAM AVE

LAUREL HILL TERRACE

10TH AVE

LAUREL HILL TERRACE

HARLEM RIVER DRIVE

HARLEM RIVER



NYC Parks



## Highbridge Park | Conceptual Master Plan - North Section

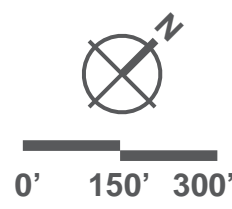



**Parks**

# **HIGHBRIDGE PARK**

**ANCHOR PARKS PROGRAM:**

**PHASE 1 CAPITAL PROJECT**

Located between Laurel Hill Terrace/ Amsterdam Avenue and Harlem River Drive, in the Borough of Manhattan

Community Board 12 Parks & Cultural Affairs Committee Presentation  
March 7, 2017

MKW + Associates, Parks Capital Design



# Goals

- Reinstate access to a 10-block stretch of the park
- Improve connectivity and pathways
- Make entrances, paths and trails more accessible
- Restore historic Grand Staircase at Laurel Hill Terrace
- Provide ADA accessibility at Grand Staircase terrace
- Improve safety and security with new park lighting
- Stabilize stone walls and edging
- Provide benches in scenic locations
- Create new community gathering spaces
- Reconnect community to the rich ecology / forest of the park
- Reconnect community to the historic elements of the park

**Total Budget:** \$10M - Phase 1

Mayoral Funding FY17

**Project Size:** 6.14 acres



NYC Parks



**Anchor Parks**

**Highbridge Park | Phase1 | Project Goals**



**SUMMARY**

Connectivity, Paths, & Entrances	131
Natural Areas & Gathering Areas	104
Upkeep & Repair Park Amenities	75
Multiuse Soccer / Football Field	53
Playspaces and Programming	46
Bathrooms	33
Lighting	32
<b>TOTAL</b>	<b>474</b>



Community Visioning Session, November 28, 2016



NYC Parks



**Anchor Parks**

**Highbridge Park | Phase1 | Community Visioning Session**

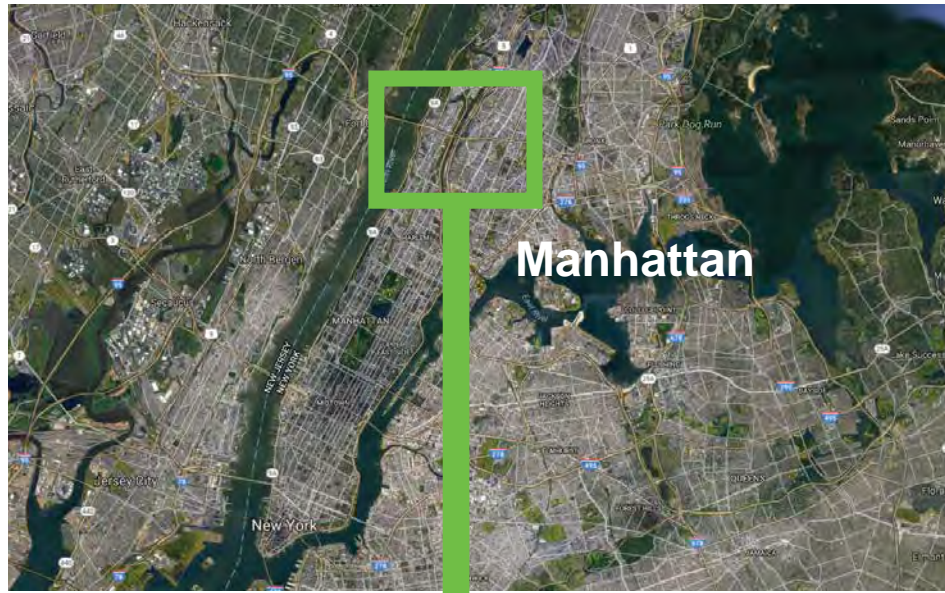

Manhattan

City

2 MI



Highbridge Park

Neighborhood

1000 FT



HUDSON HEIGHTS

Yeshiva University

Site

500 FT



NYC Parks



**Anchor Parks**  
**Highbridge Park | Phase 1 | Site Location**



## Flood Hazard Zones

- ZONE A** - 1% annual-chance flood event. No Base Flood Elevation (BFE) exists.
- ZONE AE** - 1% annual-chance flood event. BFE exists.
- ZONE AO** - 1% annual-chance shallow flooding.
- VE** - Areas along coasts subject to inundation by the 1% annual-chance flood event with additional hazards associated with storm-induced velocity wave action. BFE exists.
- FLOODWAY** - watercourse reserved to discharge base flood.
- ZONE X** - Moderate risk areas within the 0.2% annual-chance floodplain.
- LIMIT OF MODERATE WAVE ACTION**



NYC Parks



## Anchor Parks Highbridge Park | Phase 1 | Flood Risk

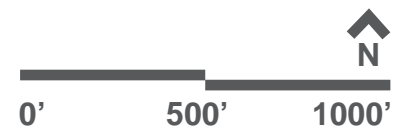

## Land Use Categories

- 1 And 2 Family Residential
- Multi-Family Residential
- Mixed Use
- Open Space And Outdoor Recreation
- Commercial
- Institutional
- Industrial
- Parking
- Transportation / Utilities
- Vacant Lots



NYC Parks



## Anchor Parks Highbridge Park | Phase 1 | Surrounding Land Use

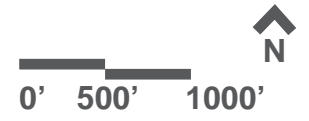

**Fort Tryon Park**

- Basketball (2)
- Playground (2)
- Fitness equipment
- Bathroom (2)
- Spray shower

**Gorman Park**

**Fort Washington Park**

- Barbecuing Areas
- Basketball
- Soccer
- Volleyball
- Baseball (2)
- Handball (8)
- Playgrounds
- Tennis (10)

**Bennett Park**

- Playground
- Bathroom

**University Woods**  
Dog-friendly Areas

**Cedar Playground**

- Basketball Court
- Fitness Equipment
- Spray Shower
- Bathrooms
- Playground

**Beanstalk Playground**

- Playground

**Morton Playground**

- Playground

**Galileo Playground**

- Playground
- Spray Shower

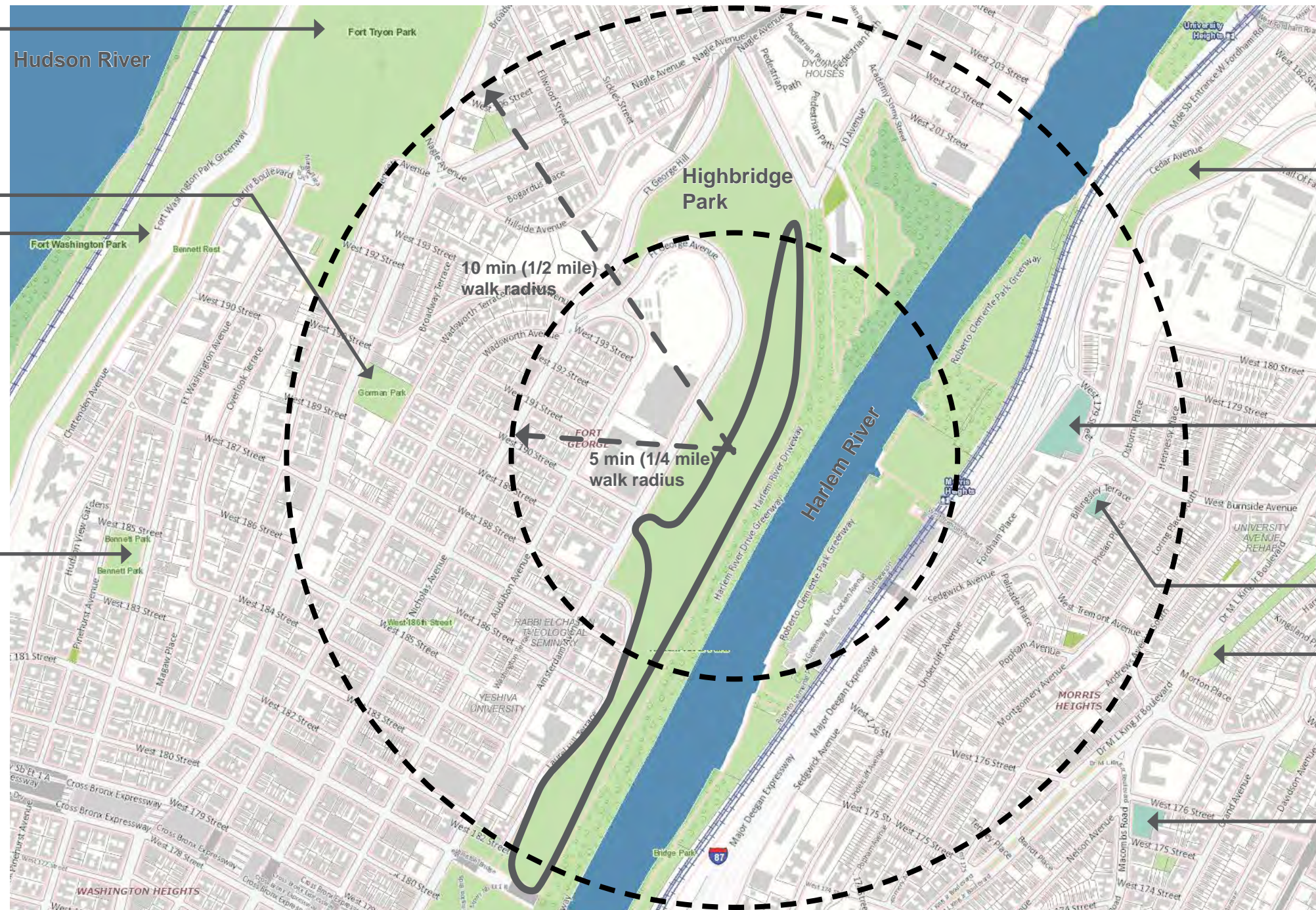

NYC Parks



**Anchor Parks**

**Highbridge Park | Phase 1 | Neighborhood Context**



**LEGEND**

- PROJECT LIMITS
- PATHS
- STAIRS
- TRAILS
- ROADS
- NO PARK ACCESS
- STEEP SLOPE
- PARK ENTRANCE
- SPOT ELEVATION
- LIMIT OF PHASE 1
- BUILDING + STRUCTURES
- OPEN SUNNY PLAY AREA
- OUTDATED PLAY EQUIPMENT
- HEAVY TRAFFIC CROSSING
- UNDERPERFORMING SOCIAL SPACE
- SPRAY SHOWER
- GATHERING
- OVERLOOK / VIEW
- BATHROOM
- BASEBALL
- BASKETBALL
- PLAYGROUND
- MOUNTAIN BIKE TRAILS
- BMX BIKE PARK
- DOG PARK

**Anchor Parks**  
**Highbridge Park | Phase 1 | Site Analysis**

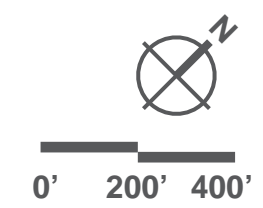



1 - Typical path configuration and materials to the South of the Grand Staircase at 184th Street.



2 - View of upper terrace of Grand Staircase at 184th Street including step up from sidewalk level.







3 - View from upper terrace of Grand Staircase to existing lower walk and the High Bridge beyond.



4 - View of the Grand Staircase at 184th Street.





5 - View illustrating the relationship between the mid-level walk of Highbridge Park, the Grand Staircase at 184th Street and Laurel Hill Terrace.



6 - Typical pathway alignment, grade and adjacencies of rubble stone walls and curbs.



NYC Parks



**Anchor Parks**  
**Highbridge Park | Phase1 | Site Photos**



7 - Stone retaining walls are a blend of dry-laid and mortared components and may include integrated rock outcrops.



8 - One of the taller heights of existing retaining walls along a steep downslope, protected by fencing.





9 - The pathway on the left slopes up to Amsterdam Avenue while the one on the right continues through the mid-level of Highbridge Park.



10 - A series of stone terraces occurs along a narrower portion of the path (12' wide) in which trees have volunteered over time. Poor pavement condition is typical along this northern section.



NYC Parks



**Anchor Parks**  
**Highbridge Park | Phase1 | Site Photos**



11 - Poor pavement condition is typical along this northern section.



12- The path down to Harlem River Drive becomes more open.





13 - As the path approaches the Harlem River Drive/Dyckman Street intersection, the wooded character along it becomes more transparent.



14 - Lower path to Harlem River Drive/Dyckman Street becomes less wooded and more park-like.



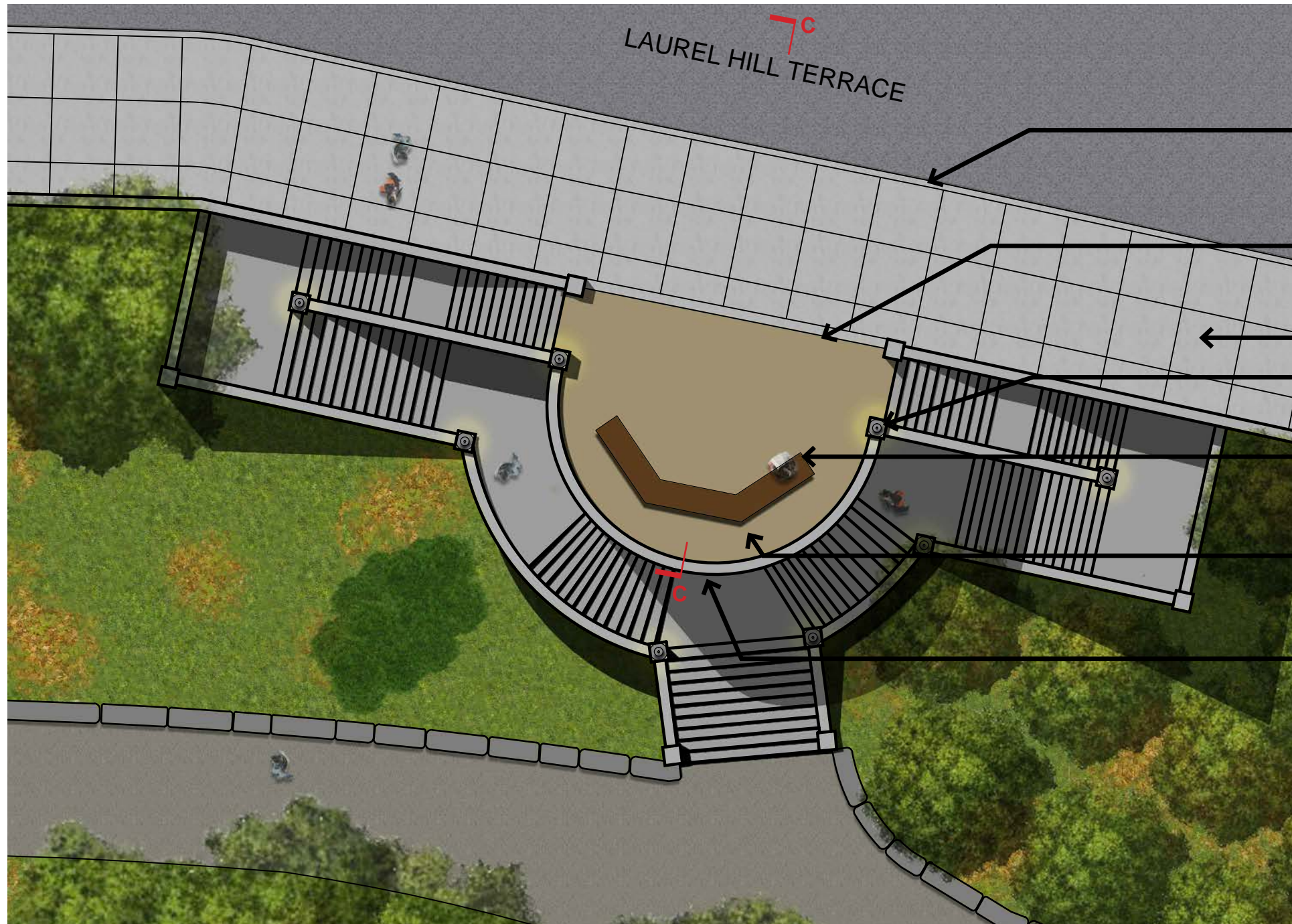

New Concrete Street Curb set to maximum allowable reveal

New Concrete Sidewalk set flush with existing Terrace edge

5' x 5' Scoring pattern

Restore historic pier-mounted lighting to illuminate plaza

1939 Angled World's Fair Bench with back

Existing Terrace to remain

Existing Parapet Wall

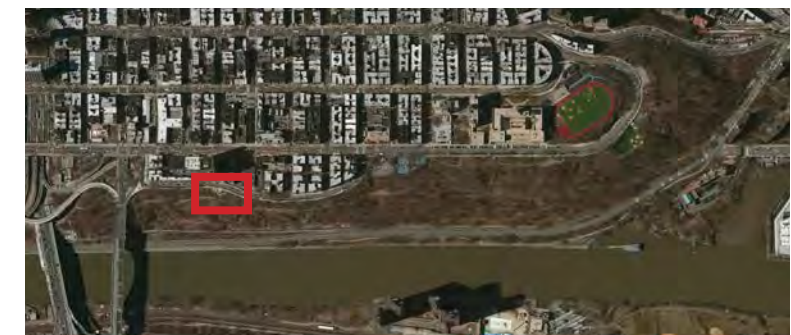

NYC Parks



**Anchor Parks**

**Highbridge Park | Phase1 | Detail Plan - Terrace at The Grand Staircase**



Restore historic pier-mounted lighting to illuminate plaza

1939 Angled World's Fair Bench with back

Existing Terrace to remain

Existing Parapet Wall



New Concrete Sidewalk set flush with existing Terrace edge

New Concrete Street Curb set to maximum allowable reveal



Existing Conditions



NYC Parks



### Anchor Parks

## Highbridge Park | Phase1 | Detail Section C-C - Terrace at The Grand Staircase





# EXISTING HISTORIC GRAND STAIRCASE



# EXISTING HISTORIC GRAND STAIRCASE



NYC Parks



**Anchor Parks**  
**Highbridge Park | Phase 1 | Existing Conditions**

# EXISTING HISTORIC GRAND STAIRCASE AND PLAZA



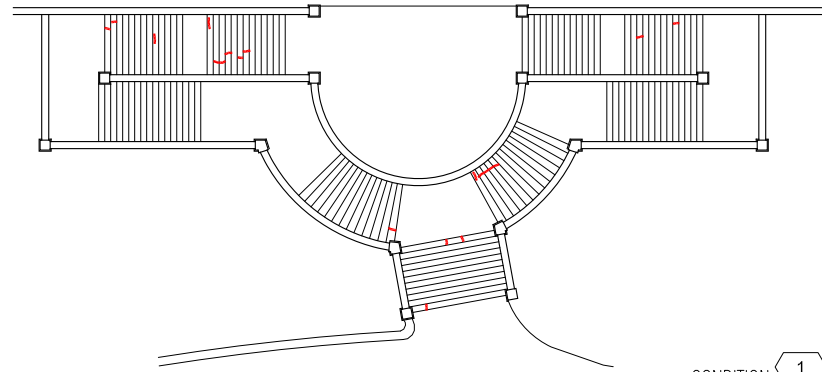

CONDITION 1

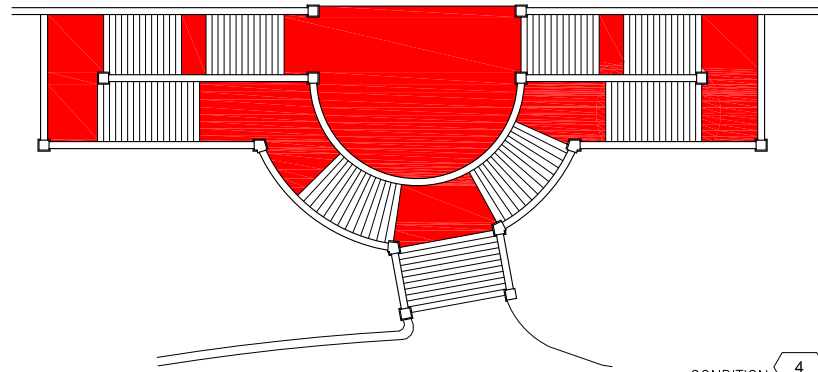

CONDITION 4

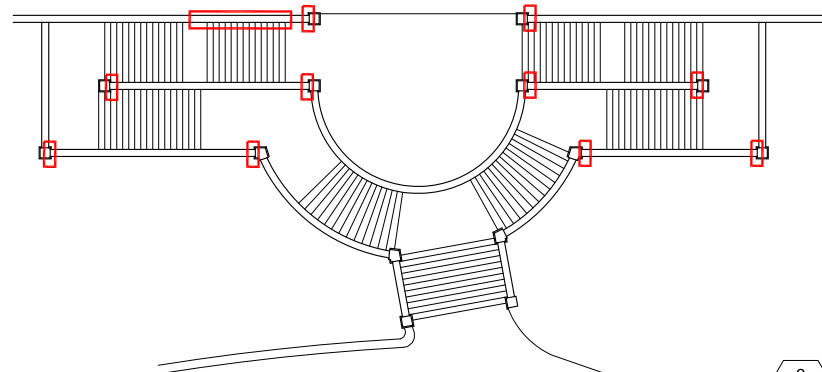

CONDITION 2

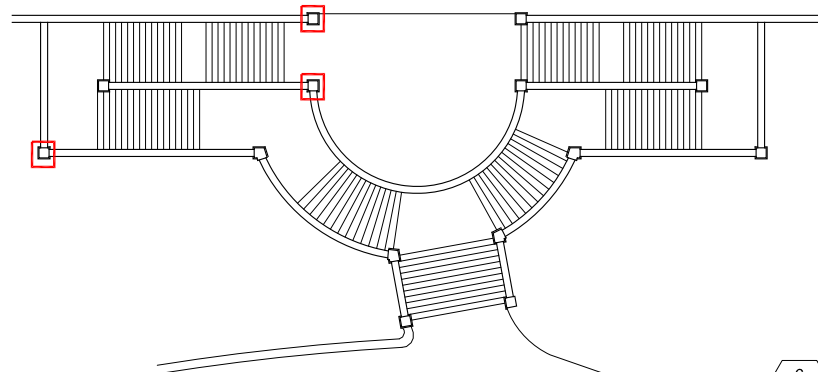

CONDITION 6

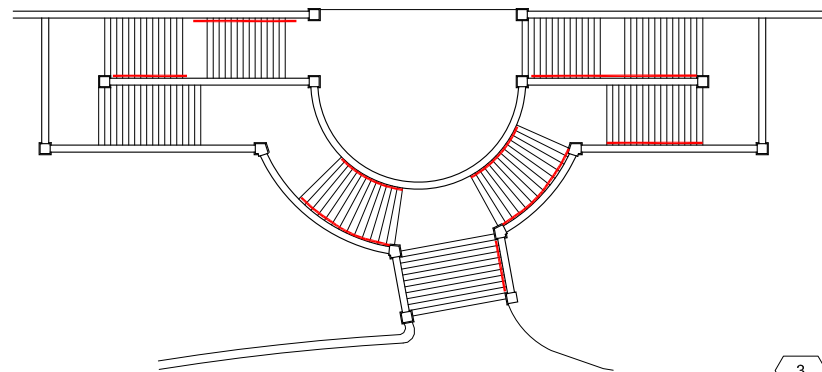

CONDITION 3

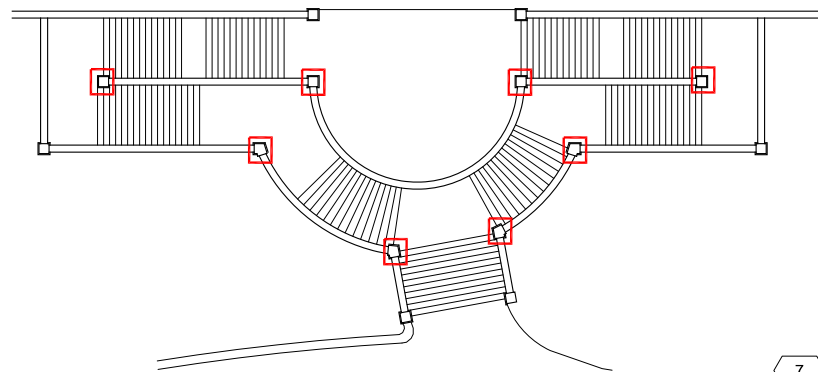

CONDITION 7

RESTORATION SCHEDULE

TAG	DESCRIPTION	PHOTO	QUANTITY
1	REPAIR CRACK ON GRANITE STEP WITH COMPOSITE MORTAR	P1.1 - P1.X	21 (EA)
2	REPAIR GRANITE PIER & PARAPET DISPLACEMENT AND REPOINT. DETERMINE UNDERLYING CAUSE OF MOVEMENT, COORDI. WITH STRUCTURAL DWGS.	P2.1 - P2.X	11 (EA)
3	REPOINT MISSING MORTAR BETWEEN GRANITE STEP AND PARAPET WITH MORTAR TO MATCH ORIGINAL MORTAR.	P3.1 - P3.X	200 (LF)
4	REMOVE FAILED PREVIOUS REPAIR ON ALL LANDINGS AND REPAIR WITH NEW MATERIAL TO MATCH ORIGINAL, COORDI. WITH STRUCTURAL DWGS.	P4.1 - P4.X	1,900 (SF) 8 LANDINGS
5	REPAIR CHIPPED/DAMAGED GRANITE STEP AND PARAPET COPING WITH COMPOSITE MORTAR	P5.1 - P5.X	-- (LF)
6	REPLACE MISSING GRANITE COPING STONE	P6.1	3 (EA)
7	INSTALL MISSING LIGHT FIXTURE AND REQUIRED ELECTRICAL	P7.1	8 (EA)
8	INSTALL NEW HANDRAIL	SK-1	320 (LF)
9	REPAIR STEP CRACK ON GRANITE BLOCK PARAPET, COORDI. WITH STRUCTURAL DWGS.	P9.1 - P9.X	9 (EA)
GRANITE STONE WALL & BLOCK PARAPET REPAIR AND CLEANING			
10	REPAIR STONE WALL CRACK, COORDI. WITH STRUCTURAL DWGS.	P10.1 - P10.X	2 (EA)
11	REPOINT 100% EXISTING JOINTS ON GRANITE WALL; REPOINT 30% EXISTING JOINTS ON GRANITE BLOCK PARAPET	P11.1 - P11.X	--
12	REPAIR MATERIAL LOSS AND VOIDS IN GRANITE WITH NEW STONE	P12.1 - P12.X	--
13	REMOVE MISC. BRICK INFILL AND REPLACE WITH GRANITE, COORDI. WITH STRUCTURAL DWGS.	P13.1 - P13.X	20 (SF)
14	REMOVE GRAFFITI AND PAINT, ABOUT 50% OF ALL GRANITE WALL AND PARAPET SURFACES	P14.1 - P14.X	50% (SF)
15	INSTALL SEALANT AT UPWARD-FACING JOINTS IN GRANITE COPING STONES	P15.1 - P15.X	--

NOTE: PHOTO REFERENCES SHOWING EXISTING CONDITIONS



NYC Parks



**Anchor Parks**  
Highbridge Park | Phase1 | Staircase Restoration

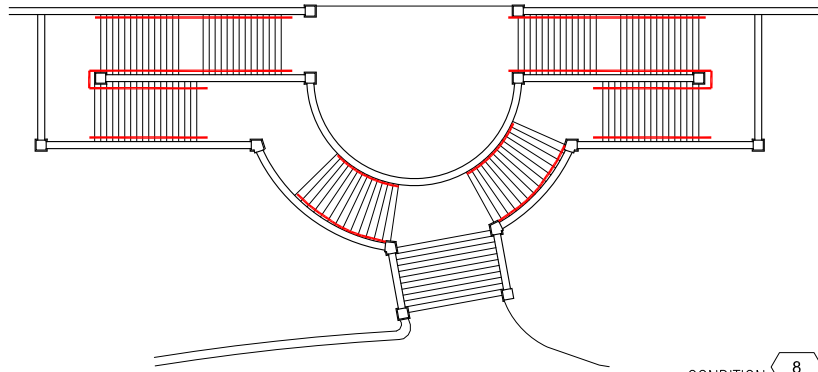

CONDITION 8

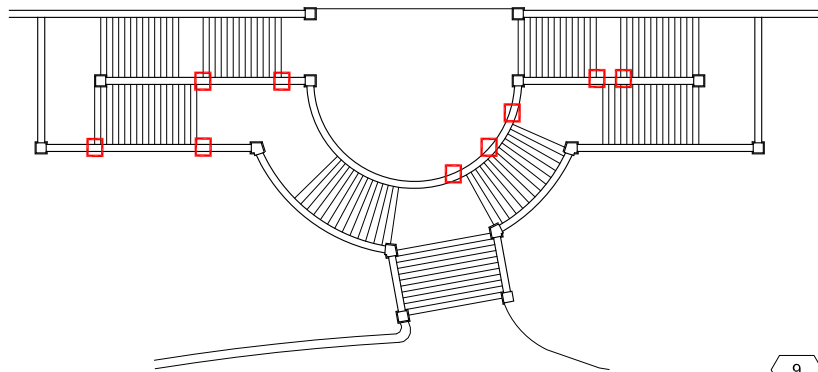

CONDITION 9

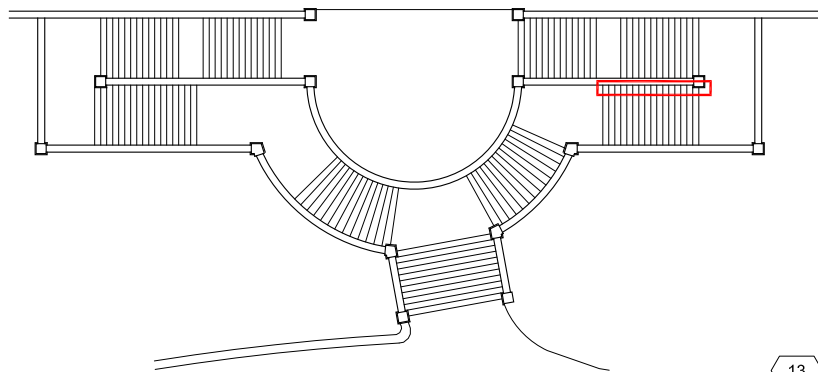

CONDITION 13

RESTORATION SCHEDULE

TAG	DESCRIPTION	PHOTO	QUANTITY
1	REPAIR CRACK ON GRANITE STEP WITH COMPOSITE MORTAR	P1.1 - P1.X	21 (EA)
2	REPAIR GRANITE PIER & PARAPET DISPLACEMENT AND REPOINT. DETERMINE UNDERLYING CAUSE OF MOVEMENT, COORDI. WITH STRUCTURAL DWGS.	P2.1 - P2.X	11 (EA)
3	REPOINT MISSING MORTAR BETWEEN GRANITE STEP AND PARAPET WITH MORTAR TO MATCH ORIGINAL MORTAR.	P3.1 - P3.X	200 (LF)
4	REMOVE FAILED PREVIOUS REPAIR ON ALL LANDINGS AND REPAIR WITH NEW MATERIAL TO MATCH ORIGINAL, COORDI. WITH STRUCTURAL DWGS.	P4.1 - P4.X	1,900 (SF) 8 LANDINGS
5	REPAIR CHIPPED/DAMAGED GRANITE STEP AND PARAPET COPING WITH COMPOSITE MORTAR	P5.1 - P5.X	-- (LF)
6	REPLACE MISSING GRANITE COPING STONE	P6.1	3 (EA)
7	INSTALL MISSING LIGHT FIXTURE AND REQUIRED ELECTRICAL	P7.1	8 (EA)
8	INSTALL NEW HANDRAIL	SK-1	320 (LF)
9	REPAIR STEP CRACK ON GRANITE BLOCK PARAPET, COORDI. WITH STRUCTURAL DWGS.	P9.1 - P9.X	9 (EA)
GRANITE STONE WALL & BLOCK PARAPET REPAIR AND CLEANING			
10	REPAIR STONE WALL CRACK, COORDI. WITH STRUCTURAL DWGS.	P10.1 - P10.X	2 (EA)
11	REPOINT 100% EXISTING JOINTS ON GRANITE WALL; REPOINT 30% EXISTING JOINTS ON GRANITE BLOCK PARAPET	P11.1 - P11.X	--
12	REPAIR MATERIAL LOSS AND VOIDS IN GRANITE WITH NEW STONE	P12.1 - P12.X	--
13	REMOVE MISC. BRICK INFILL AND REPLACE WITH GRANITE, COORDI. WITH STRUCTURAL DWGS.	P13.1 - P13.X	20 (SF)
14	REMOVE GRAFFITI AND PAINT, ABOUT 50% OF ALL GRANITE WALL AND PARAPET SURFACES	P14.1 - P14.X	50% (SF)
15	INSTALL SEALANT AT UPWARD-FACING JOINTS IN GRANITE COPING STONES	P15.1 - P15.X	--

NOTE: PHOTO REFERENCES SHOWING EXISTING CONDITIONS



NYC Parks



**Anchor Parks**  
**Highbridge Park | Phase1 | Staircase Restoration**



1 CRACK ON GRANITE STEP



4 FAILED PREVIOUS REPAIR ON LANDING



7 MISSING LIGHT FIXTURE



2 GRANITE PIER & PARAPET DISPLACEMENT



5 CHIPPED / DAMAGED GRANITE STEPS

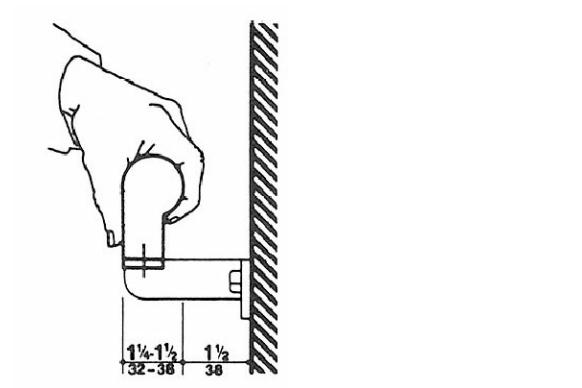

8 INSTALL SIDE-MOUNTED NEW HANDRAIL



3 MISSING MORTAR



6 MISSING GRANITE COPING



9 STEP CRACK

RESTORATION SCHEDULE

TAG	DESCRIPTION	PHOTO	QUANTITY
1	REPAIR CRACK ON GRANITE STEP WITH COMPOSITE MORTAR	P1.1 - P1.X	21 (EA)
2	REPAIR GRANITE PIER & PARAPET DISPLACEMENT AND REPOINT. DETERMINE UNDERLYING CAUSE OF MOVEMENT, COORDI. WITH STRUCTURAL DWGS.	P2.1 - P2.X	11 (EA)
3	REPOINT MISSING MORTAR BETWEEN GRANITE STEP AND PARAPET WITH MORTAR TO MATCH ORIGINAL MORTAR.	P3.1 - P3.X	200 (LF)
4	REMOVE FAILED PREVIOUS REPAIR ON ALL LANDINGS AND REPAIR WITH NEW MATERIAL TO MATCH ORIGINAL, COORDI. WITH STRUCTURAL DWGS.	P4.1 - P4.X	1,900 (SF) 8 LANDINGS
5	REPAIR CHIPPED/DAMAGED GRANITE STEP AND PARAPET COPING WITH COMPOSITE MORTAR	P5.1 - P5.X	-- (LF)
6	REPLACE MISSING GRANITE COPING STONE	P6.1	3 (EA)
7	INSTALL MISSING LIGHT FIXTURE AND REQUIRED ELECTRICAL	P7.1	8 (EA)
8	INSTALL NEW HANDRAIL	SK-1	320 (LF)
9	REPAIR STEP CRACK ON GRANITE BLOCK PARAPET, COORDI. WITH STRUCTURAL DWGS.	P9.1 - P9.X	9 (EA)
GRANITE STONE WALL & BLOCK PARAPET REPAIR AND CLEANING			
10	REPAIR STONE WALL CRACK, COORDI. WITH STRUCTURAL DWGS.	P10.1 - P10.X	2 (EA)
11	REPOINT 100% EXISTING JOINTS ON GRANITE WALL; REPOINT 30% EXISTING JOINTS ON GRANITE BLOCK PARAPET	P11.1 - P11.X	--
12	REPAIR MATERIAL LOSS AND VOIDS IN GRANITE WITH NEW STONE	P12.1 - P12.X	--
13	REMOVE MISC. BRICK INFILL AND REPLACE WITH GRANITE, COORDI. WITH STRUCTURAL DWGS.	P13.1 - P13.X	20 (SF)
14	REMOVE GRAFFITI AND PAINT, ABOUT 50% OF ALL GRANITE WALL AND PARAPET SURFACES	P14.1 - P14.X	50% (SF)
15	INSTALL SEALANT AT UPWARD-FACING JOINTS IN GRANITE COPING STONES	P15.1 - P15.X	--

NOTE: PHOTO REFERENCES SHOWING EXISTING CONDITIONS



10 GRANITE STONE WALL CRACK



13 MISC. BRICK INFILL



11 REPOINT 100% MORTAR



14 GRAFFITI AND PAINT



12 VOIDS & MATERIAL LOSS



15 UPWARD-FACING JOINT IN GRANITE COPING STONE

RESTORATION SCHEDULE

TAG	DESCRIPTION	PHOTO	QUANTITY
1	REPAIR CRACK ON GRANITE STEP WITH COMPOSITE MORTAR	P1.1 - P1.X	21 (EA)
2	REPAIR GRANITE PIER & PARAPET DISPLACEMENT AND REPOINT. DETERMINE UNDERLYING CAUSE OF MOVEMENT, COORDI. WITH STRUCTURAL DWGS.	P2.1 - P2.X	11 (EA)
3	REPOINT MISSING MORTAR BETWEEN GRANITE STEP AND PARAPET WITH MORTAR TO MATCH ORIGINAL MORTAR.	P3.1 - P3.X	200 (LF)
4	REMOVE FAILED PREVIOUS REPAIR ON ALL LANDINGS AND REPAIR WITH NEW MATERIAL TO MATCH ORIGINAL, COORDI. WITH STRUCTURAL DWGS.	P4.1 - P4.X	1,900 (SF) 8 LANDINGS
5	REPAIR CHIPPED/DAMAGED GRANITE STEP AND PARAPET COPING WITH COMPOSITE MORTAR	P5.1 - P5.X	-- (LF)
6	REPLACE MISSING GRANITE COPING STONE	P6.1	3 (EA)
7	INSTALL MISSING LIGHT FIXTURE AND REQUIRED ELECTRICAL	P7.1	8 (EA)
8	INSTALL NEW HANDRAIL	SK-1	320 (LF)
9	REPAIR STEP CRACK ON GRANITE BLOCK PARAPET, COORDI. WITH STRUCTURAL DWGS.	P9.1 - P9.X	9 (EA)
GRANITE STONE WALL & BLOCK PARAPET REPAIR AND CLEANING			
10	REPAIR STONE WALL CRACK, COORDI. WITH STRUCTURAL DWGS.	P10.1 - P10.X	2 (EA)
11	REPOINT 100% EXISTING JOINTS ON GRANITE WALL; REPOINT 30% EXISTING JOINTS ON GRANITE BLOCK PARAPET	P11.1 - P11.X	--
12	REPAIR MATERIAL LOSS AND VOIDS IN GRANITE WITH NEW STONE	P12.1 - P12.X	--
13	REMOVE MISC. BRICK INFILL AND REPLACE WITH GRANITE, COORDI. WITH STRUCTURAL DWGS.	P13.1 - P13.X	20 (SF)
14	REMOVE GRAFFITI AND PAINT, ABOUT 50% OF ALL GRANITE WALL AND PARAPET SURFACES	P14.1 - P14.X	50% (SF)
15	INSTALL SEALANT AT UPWARD-FACING JOINTS IN GRANITE COPING STONES	P15.1 - P15.X	--

NOTE: PHOTO REFERENCES SHOWING EXISTING CONDITIONS

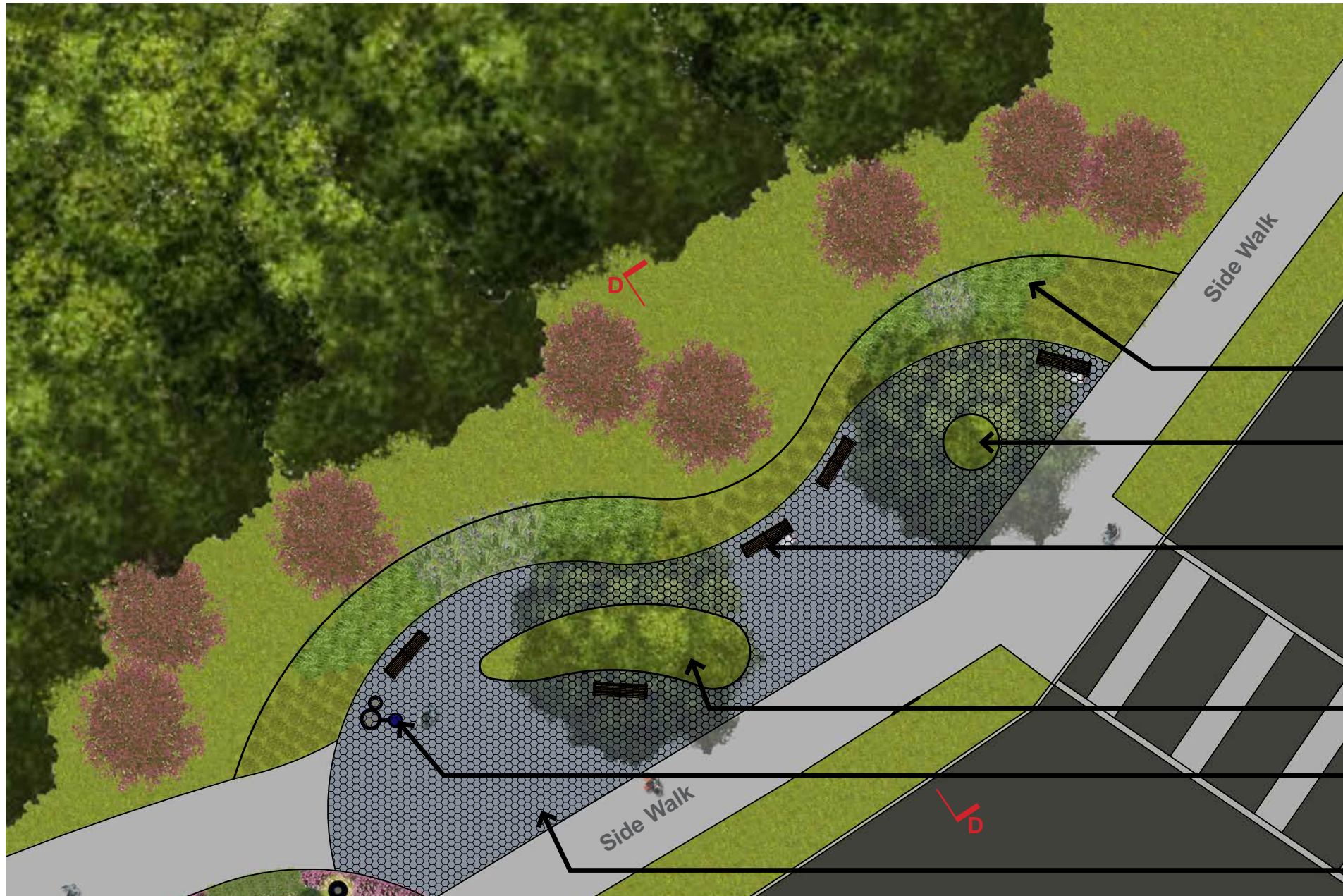

- Rain Garden
- Existing Sycamores
- 8' long 1939 World's Fair Bench with back
- Low Plant Bed
- Bottle Filler / Drinking Fountain
- Asphalt Block Pavement



**Anchor Parks**  
**Highbridge Park | Phase 1 | Detail Plan - Entrance at Harlem River Drive and Dyckman Street**





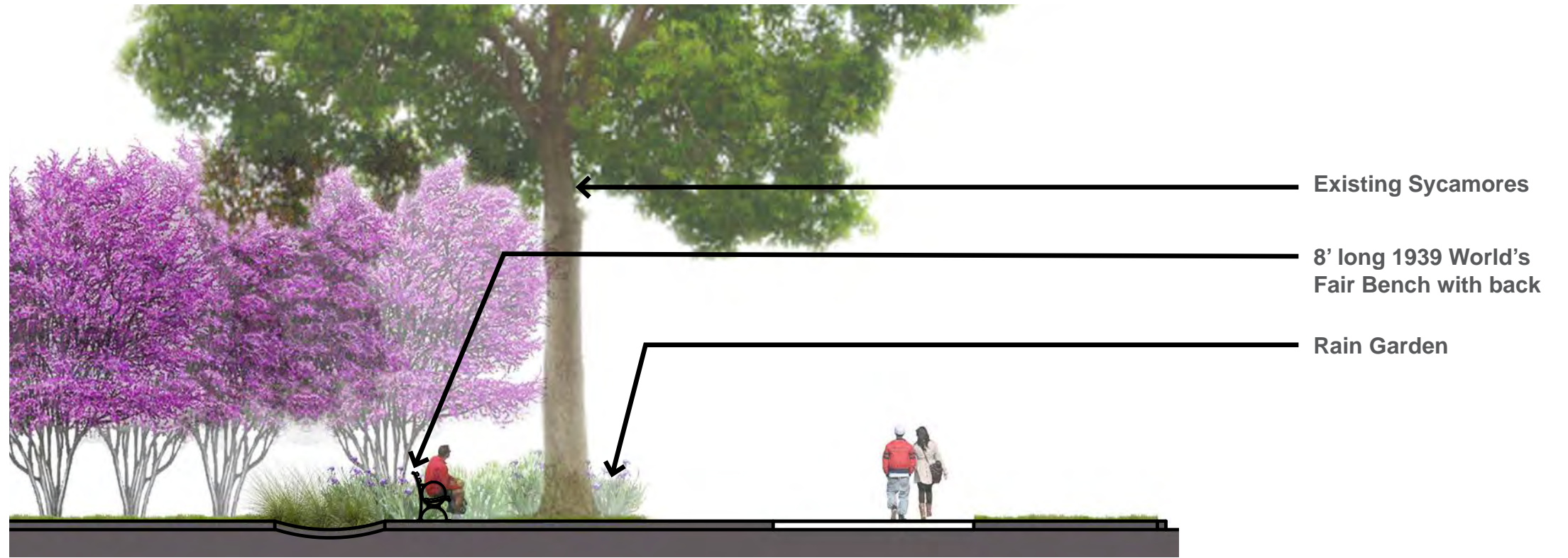

Existing Conditions

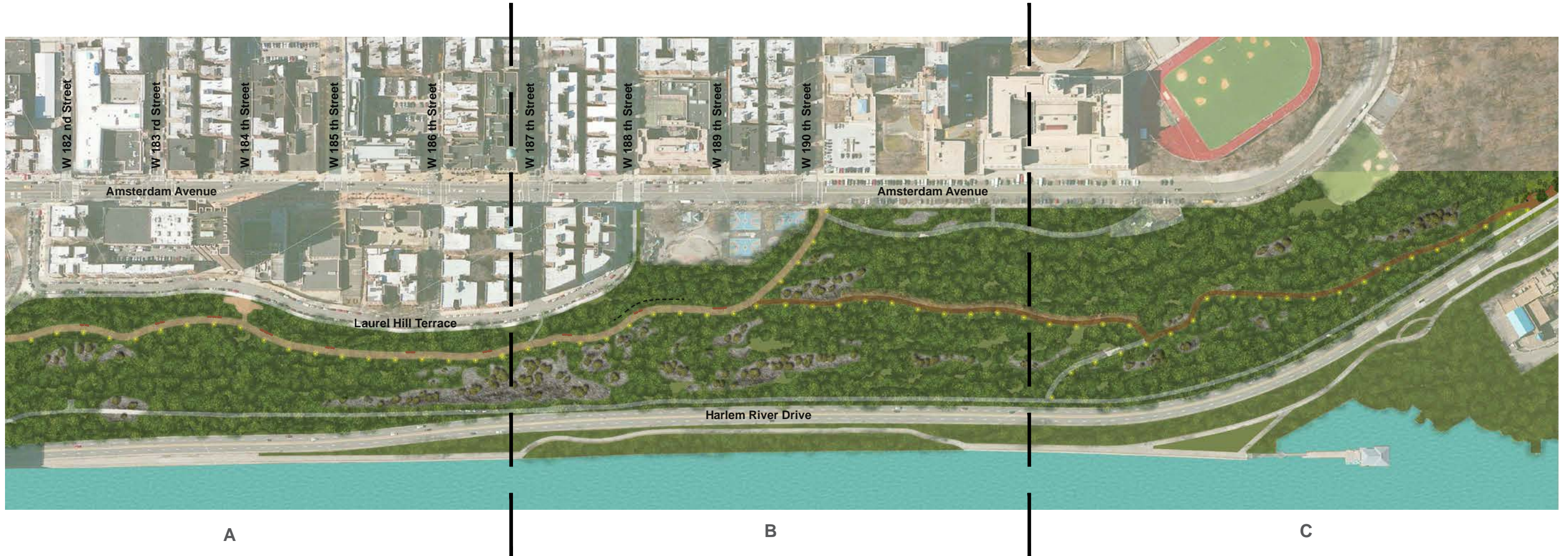

**Anchor Parks**  
**Highbridge Park | Phase 1 | Phase 1 Plan - Overall**

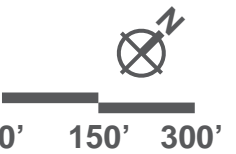

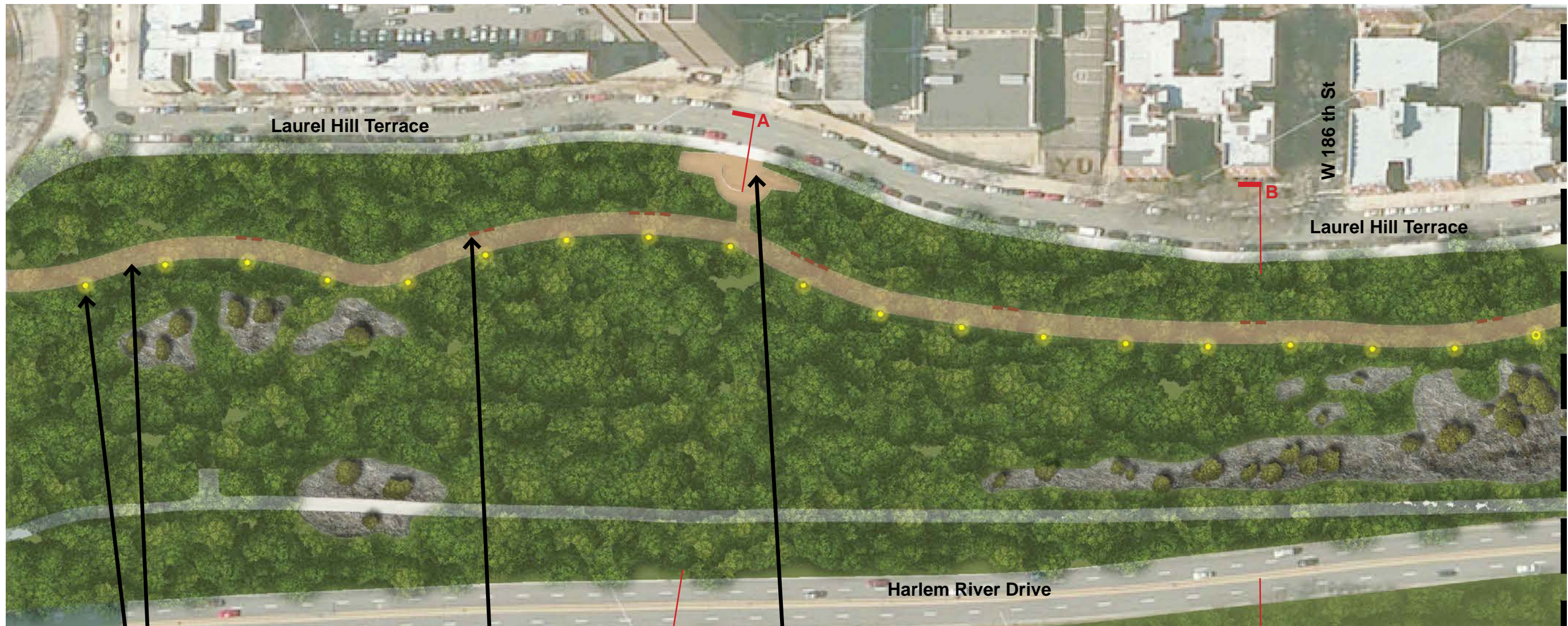





Asphalt Top Coat

Type B Light Pole / Fixture  
at 75' on center ±

8' Long 1939 World's Fair  
Benches with Backs

Detail Plan - Terrace at  
Grand Staircase

**Legend**

-  New Benches
-  New Light Poles
-  Full Depth Asphalt Pavement
-  Asphalt Top Coat



NYC Parks



**Anchor Parks**  
Highbridge Park | Phase 1 | Phase 1 Plan - A

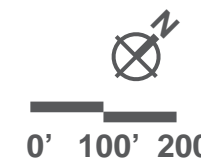



W 187 th St

Laurel Hill Terrace

Amsterdam Avenue

MATCHLINE

MATCHLINE

Asphalt Top Coat

Type B Light Pole / Fixture  
at 75' on center ±

8' Long 1939 World's Fair  
Benches with Backs

Full Depth Asphalt  
Pavement

**Legend**

- - - New Conc. Curb with 4' Steel Fence
- New Benches
- New Light Poles
- Full Depth Asphalt Pavement
- Asphalt Top Coat



NYC Parks



**Anchor Parks**  
Highbridge Park | Phase 1 | Phase 1 Plan - B

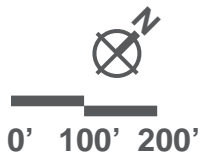

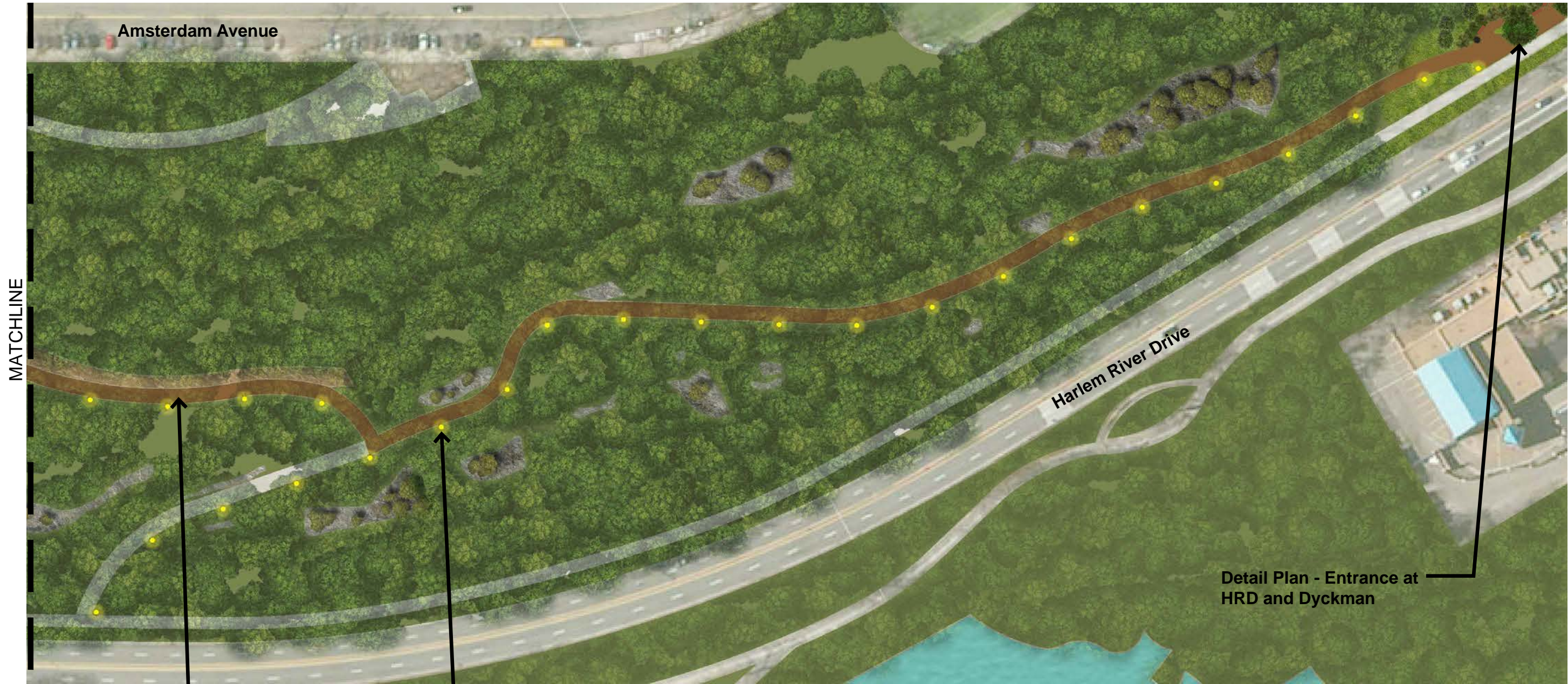



Full Depth Asphalt Pavement

Type B Light Pole / Fixture at 75' on center +

Legend

-  New Benches
-  New Light Poles
-  Full Depth Asphalt Pavement
-  Asphalt Top Coat

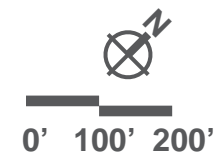

**Anchor Parks**  
**Highbridge Park | Phase 1 | Phase 1 Plan - C**



NYC Parks



## Anchor Parks

### Highbridge Park | Phase 1 | Site Section A-A - At Grand Staircase





**Anchor Parks**  
**Highbridge Park | Phase 1 | Site Section B-B**



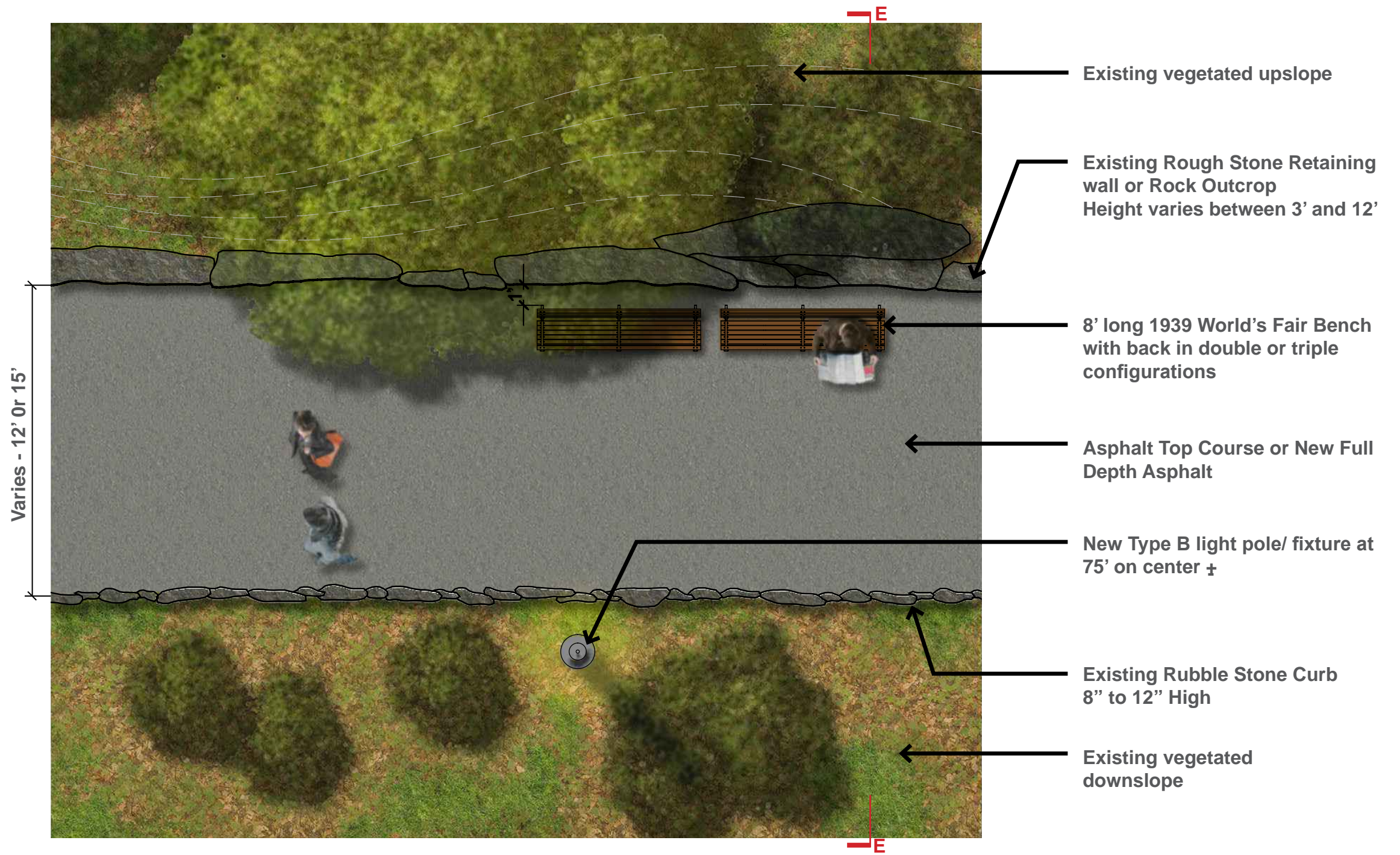





NYC Parks



**Anchor Parks**  
**Highbridge Park | Phase1 | Typical Site Section E - E**





**Asphalt Pavement**



**Asphalt Block Pavers**



**Concrete Pavement**



**4'-0" Steel Fence**



**1939 World's Fair Bench with Back**



**Bottle Filler with Hi-Lo Drinking Fountains**



**Type B Light Pole and Fixture**



NYC Parks



**Anchor Parks**  
**Highbridge Park | Phase 1 | Site Furnishings**

# WHAT COMES NEXT?

- **Submit Phase 1 project to the Public Design Commission**
- **Continue design of Phase 1 project throughout 2017**
  - **Begin the Phase 2 project in May**





**THANK YOU!**